

Customer hotline:  400-619-2001

EXCELLENT & SMART

Create a better life with smart drive

**CUMARK**  
SHENZHEN CUMARK SCI. & TECH. CO., LTD.  
Cumark Building, 68 Guangdian East Road, Guangming  
District Shenzhen, China  
Postalcode : 518107  
Tel : 0755-81785111  
Fax : 0755-81785108  
Website : www.cumark.com.cn

Distributor

All rights reserved © Shenzhen Cumark Sci. & Tech Co., Ltd.

© Copyright 2023 Cumark. Technical specifications are subject to change without further notice. 36080282 Edition C English 2023-02-17



Low-voltage Frequency Converter Series | High-voltage Frequency Converter Series  
Explosion-proof Frequency Converter Series | System Solutions

# ES Series

## High-performance Vector Control Low-voltage Frequency Converter



Official website WeChat public platform

# ES Series Frequency Converter

*Excellent & Efficient  
Intelligence Drives the Future*

Cumark elaborately produces ES series high-performance vector frequency converters, based on many years of experience accumulation in electric drive R&D and various industrial automation applications, in combination with internationally first-class drive technologies.

ES series products can meet industrial control demands from different fields under severe environments with their high performance, rich functions and perfect structures, and provide all-round competitive advantages including excellent quality, friendly human-machine interface, and convenient services.

## CONTENTS >>>

Company Profile	01
List of ES Series Frequency Converters	02
Product advantages	03
• High Reliability	03
• Excellent Performance	05
• Rich Functions	07
• Modular Compact Design	09
• Smart Drive	10
Designation Rules	10
Technical Data	11
Product Selection	19
• General-purpose vector low-voltage variable frequency drive series products	19
• High-performance industrial variable frequency drive series products	21
• High Power Servo Driver	26
Installation Dimensions	27
Optional Accessories	28
Standard Wiring Diagrams	29
Advantageous Industry Applications	33
Cumark full range of services	35



fault diagnosis

industry applications  
parameters



Control Keyboard

monitoring

curve setting

## Company Profile

SHENZHEN CUMARK SCL& TECH CO.,LTD. was founded on March 19, 2001. It has been focusing on R&D, production and sales of power electronic transmission and automation products. It is a national high-tech enterprise and awarded as "special frequency conversion engineering technology R&D center of Guangdong Province". It relies on excellent technology and many years accumulated industry application experience, and provides users with efficient and reliable intelligent drive products and complete automation solutions.



CUMARK's high, medium and low voltage series of intelligent frequency inverters and their related automation integrated products have a wide range of application prospects. They can be widely used in CNC machine tools and robots, marine engineering equipment, ships, rail transit equipment, Energy-saving and new energy vehicles, agricultural machinery and equipment, logistics and warehousing, electric power, coal, petrochemical, chemical, environmental protection, pharmaceuticals, non-ferrous metals, steel and other fields can help manufacturers improve equipment automation, energy conservation and efficiency, and reduce production costs, help the equipment manufacturing industry products green and intelligent upgrades and improve market competitiveness.

## Service Network



## List of ES Series Frequency Converters

Type	Performance	Target market	Series	Appearance
General-purpose vector low-voltage variable frequency drive	<ol style="list-style-type: none"> <li>1) Standard configuration STO safety torque off function</li> <li>2) Support V/F and SVC vector control</li> <li>3) Support permanent magnet synchronous motor/asynchronous motor control</li> <li>4) Standard G3 filter</li> <li>5) Large screen LCD or LED keyboard can be connected externally</li> <li>6) All DI terminals both support PNP &amp; NPN input, DI4 supports 60kHz high-speed input</li> <li>7) Standard configuration of magnetic flux braking function</li> <li>8) The carrier frequency can be adjusted intelligently according to the temperature</li> </ol>	Food Machinery; Textile machinery; Small water pump; Packaging Machinery; food processing; Wood carving; Blower; Logistics machinery; Electronics manufacturing; etc.	ES355(Asynchronous) ES355L(Asynchronous & PM Synchronous) 220V 1PH 0.4~2.2kW 220V 3PH 0.4~2.2kW 380V 3PH 0.75~4.0kW	
	<ol style="list-style-type: none"> <li>1) High reliability</li> <li>2) Easy operation</li> <li>3) Open-loop control &amp; vector control</li> <li>4) Compatible permanent magnet synchronous &amp; 3phase asynchronous motor</li> <li>5) Built in digital LED keyboard, optional Intelligent LCD display</li> <li>6) Modular compact structure design</li> </ol>	Ceramic equipment ; Dyeing & finishing equipment ; Woodworking machinery ; Glass mechanical ; Logistic & warehousing ; Extrusion equipment ; Food machinery ; Textile machinery ; Rubber machine ; Conveyor ; Centrifuge ; Compressor ; Fan ; Pump ; etc.	ES560 (Asynchronous motor) ES560 L (Asynchronous, Synchronous) 380V 3PH 5.5~630KW	
High-performance industrial variable frequency drive	<ol style="list-style-type: none"> <li>1) Small size and compact;</li> <li>2) Easy commissioning, optional intelligent LCD keyboard;</li> <li>3) Built-in RS485 communication included in standard configuration;</li> <li>4) High-performance PID function;</li> </ol>	Small water pumps, Food packing, Food processing Wood working and engraving ; Air blower, etc.	ES350 (Asynchronous motor) ES350L (Synchronous motor) 220V 1PH 0.4-2.2KW 380V 3PH 0.75-4KW	
	<ol style="list-style-type: none"> <li>1) High reliability;</li> <li>2) precision control</li> <li>3) Compatible with permanent magnet synchronous motor drive and three-phase asynchronous motor drive;</li> <li>4) Intelligent LCD keyboard included in standard configuration;</li> <li>5) Modular compact structure design</li> </ol>	Ceramic equipment, Dyeing and finishing, Logistics sorting, woodworking machinery, glass machinery, food machinery, equipment, air compressor, Centrifuge Textiles Fans Pumps, etc.	ES580 (Asynchronous motor) ES580L (Synchronous motor) 220V 3PH 0.4-75KW 380V 3PH 0.75-800KW 500V 3PH 15-900KW 690V 3PH 15-1400KW	
	<ol style="list-style-type: none"> <li>1) Excellent performance;</li> <li>2) Rich functions;</li> <li>3) High reliability;</li> <li>4) Comprehensive and systematic protection functions;</li> <li>5) Intelligent LCD keyboard included in standard configuration;</li> <li>6) Built-in various industry application standard macros;</li> <li>7) Support multiple encoders for high performance and high precision control</li> </ol>	Hoisting and lifting, Digitally controlled, machine tools, Forging machine tools, Roots blower, Food machinery, Textiles, Dyeing and finishing, Plastic machine, HVAC, Petroleum, Chemical engineering, Medical, etc.	ES850 (Induction motor) ES850L (Asynchronous motor, Synchronous motor) 220V 3PH 0.4-75KW 380V 3PH 0.75-800KW 500V 3PH 15-900KW 690V 3PH 15-1400KW	
High Power Servo Driver	<ol style="list-style-type: none"> <li>1) Support driving asynchronous motor and permanent magnet synchronous motor;</li> <li>2) The highest output frequency can reach 1500Hz;</li> <li>3) Support multiple encoders and fieldbus;</li> <li>4) With high precise speed and position control;</li> <li>5) With the function of fixed length and fixed angle;</li> <li>6) Pulse input and pulse output;</li> </ol>	CNC machine tool, Machining Center, Gantry machine tool, CNC grinder, High speed fan, Hydrogen energy equipment, etc.	ES850S 220V 3PH 0.4-15KW 380V 3PH 0.75-55KW	

## Innovative Thermal Design Philosophy and Professional Thermal Simulation Analysis

- The innovative thermal design philosophy and first-class efficient thermal simulation software bring about the innovative and unique design, which provides this product with a comprehensive and systematical heat dissipation structure and solution.
- Advanced heat test and verification technologies like thermal imaging efficiently and completely check theoretical results of the thermal design, and further guarantee thermal reliability of the product system.

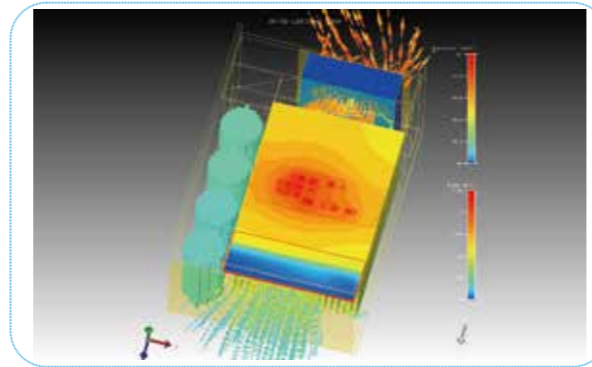

## Rigorous Temperature Rise Test on the Whole Converter

- Rigorous testing procedures for full load and overload verification as well as strict temperature rise acceptance standards for key components are adopted to enable the product to operate reliably under extreme overload conditions for a long time.
- High temperature aging testing with 120%(G)/100% (P) at 40°C
- All products shall pass the loaded high temperature aging test before delivery, which can effectively prevent scattered components from being invalid, and guarantee product quality.

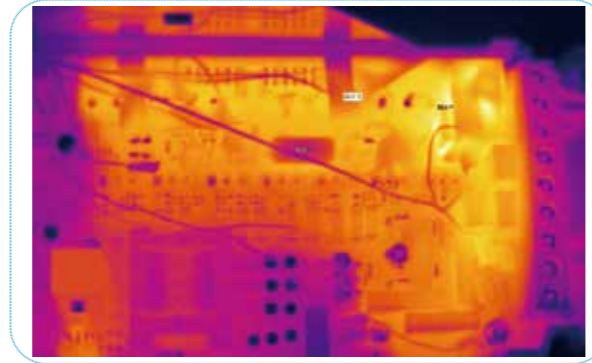

## Spraying Process of Conformal Coatings

- Multiple high-quality conformal coatings are sprayed to enhance the product's good applicability to the environment.
- The automatic spraying process of conformal coatings is adopted to effectively ensure uniform coating thickness of the circuit board and consistency of batched products.



Note: The automatic spraying process of conformal coatings

## High Protection Grade

- Especially applied in cables, machine tools, ceramics and textiles industries where the site environments are severe, humid or dusty. The innovative and tightly closed structure design can effectively reduce influence of such environments.
- The protection class can reach IP41(0.4-22KW).



## High Anti-interference Capability

- In a standard configuration, the optimally designed built-in DC reactor (15KW and above) can effectively reduce interference from higher harmonic and foreign conduction radiation and strengthen the power grid adaptability.
- In a standard configuration, the built-in input C3 filter is equipped to reduce electromagnetic interference and guarantee steady operation of the device.
- Simple and friendly EMC cut-off point structure designs convenient for grounding and weakens electromagnetic interference.



## Wide Voltage Range Design

- Rated voltage: single phase 220V; three-phase 220V/380V/500V/690V
- Voltage frequency: 50-60Hz±5Hz
- Allowable voltage fluctuation: -15% to +15%

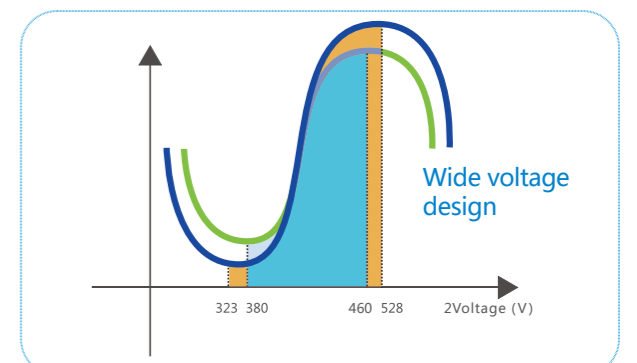

## Innovative and Independent Air Duct Design

- The design can effectively prevent dust and other foreign matters from entering the inside of the frequency converter, thereby avoiding faults caused by electric short circuits and damaged components.
- Electronic components are separated from the main cooling system by the poor conductor or wind screen, to avoid component failures due to too high temperature caused by heat radiation from the main-power radiator.

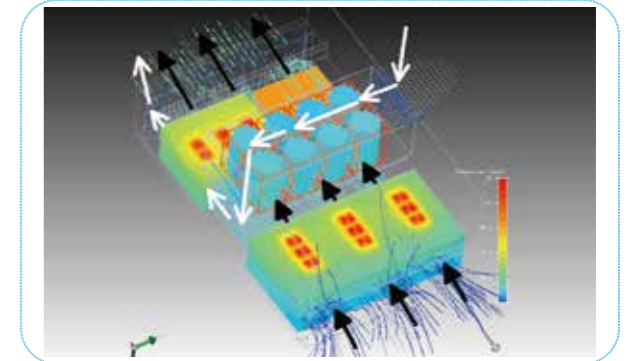

## Selection and Design of Key Components

- Strict component selection testing procedures are adopted. All power components such as the rectifier bridge, IGBT and electrolytic capacitor use mainstream products of the first-class manufacturers. Performance and reliability of key components are guaranteed from selection to manufacturing
- Large allowance and derating design ensures reliability of key components.

## CE Certification Compliance

- The ES series products meet relevant requirements of European CE directives.

# Excellent Performance

## Comprehensive Motor Drive Technology

- Support drive control of all motors (three-phase asynchronous, permanent magnet synchronous).
- Support the speed and torque control modes.
- The frequency converter equipped with the synchronous motor delivers good energy-saving effects.

## Built-in Servo Function

- The built-in servo positioning is adopted for the device. When the PG vector control is available, the device supports control over positions including zero servo, principal axis orientation (4 orientation positions), simple carry control (8 carryovers setting) and pulse train position.
- Servo functions such as spindle positioning at any angle and stop at a specified angle can be realized.
- It can be used in most servo application fields.

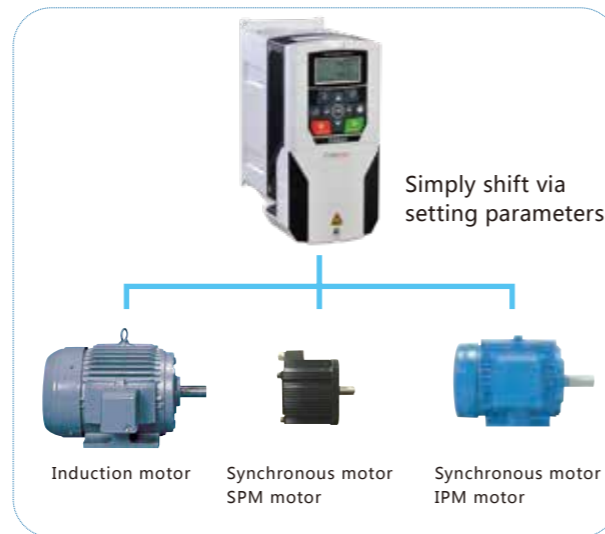

## Accurate and Comprehensive Auto-tuning Function

- The frequency converter can accomplish motor parameter auto-tuning accurately, it will be more convenient to operate & commissioning and offers higher control precision and response speed.
- The comprehensive and rich Auto-tuning functions cover various motor Auto-tuning and mechanical Auto-tuning functions.

Motor Comprehensive Auto-tuning	
Rotary Auto-tuning	Mostly suitable in applications of high starting torque, high speed and high control precision.
Static Auto-tuning	Mostly suitable in applications of commissioning when the motor and handling machines are connected.

## Rich Fieldbus Communication

- Built in RS-485
- Built-in Modbus-RTU as standard
- Support several kinds of field bus communication protocols (PROFIBUS-DP, CANopen, Profinet, EtherCAT)



Turn complex into simple, computer monitoring software

## Large Startup Torque

- Synchronous motor  
Open-loop vector : 0.5Hz/200%  
Close-loop vector : 0Hz/200%
- Asynchronous motor  
Open-loop vector : 0.25Hz/200%  
Close-loop vector : 0Hz/200%

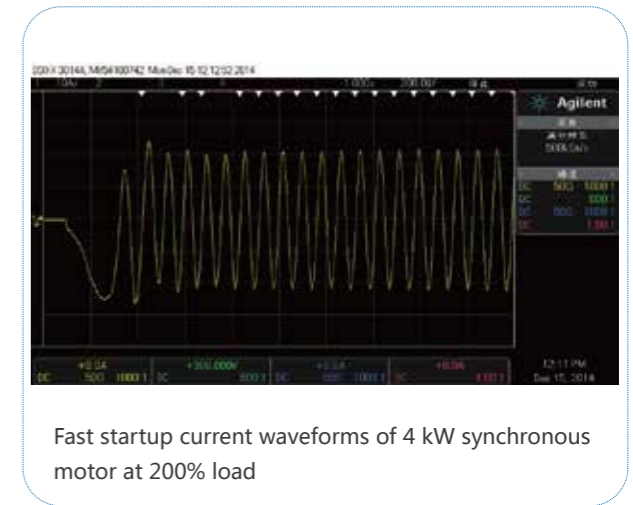

Fast startup current waveforms of 4 kW synchronous motor at 200% load

## Fast Torque Response, Low Torque Pulse

- Torque response open-loop vector : <20ms
- Torque response close-loop vector : <5ms
- The device can run steadily with load at a ultra-low speed of 0.01Hz. The low torque pulse ensures stable running.

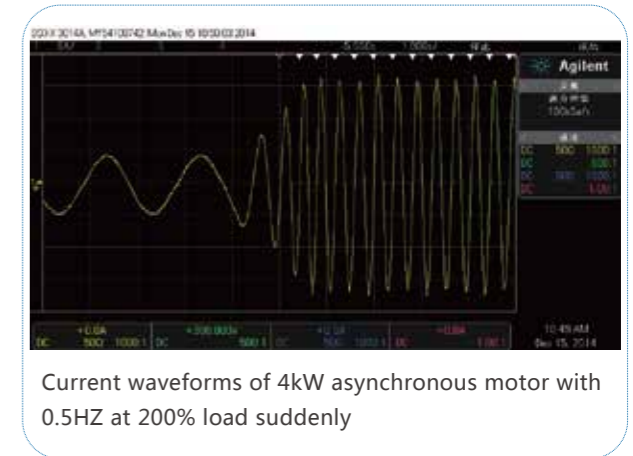

Current waveforms of 4kW asynchronous motor with 0.5Hz at 200% load suddenly

## Wide Speed Range, High Steady-speed Precision

- Speed range :  
Open-loop vector : 1 : 200  
Close-loop vector : 1 : 3000
- Steady-speed precision :  
Open-loop vector : 10% rated slip  
Close-loop vector : ± 0.01%

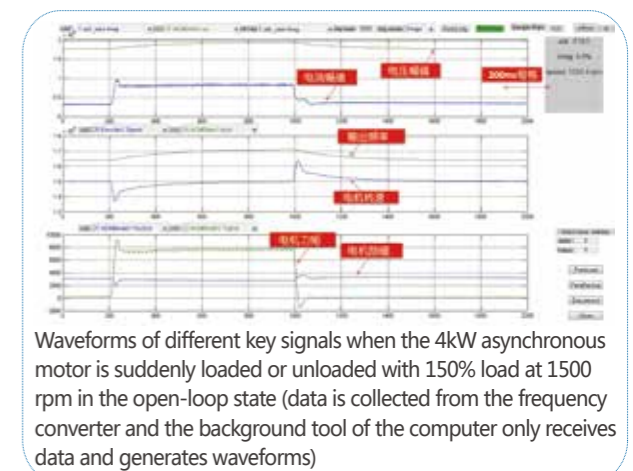

Waveforms of different key signals when the 4kW asynchronous motor is suddenly loaded or unloaded with 150% load at 1500 rpm in the open-loop state (data is collected from the frequency converter and the background tool of the computer only receives data and generates waveforms)

## High Overload Capacity

- Run steadily at 120% rated load
- Run for 60s at 150% rated load

## LCD Smart Keyboard Adopted in Standard Configuration/optional LED keypad

- Large-text and multi-function Chinese or English LCD display for faster and more accurate parameter settings.
- Detailed status display for monitoring and setting.
- Detailed diagnosis information. Status information and waves of key nodes, fault records, and diagnosis information can be viewed for fault query and maintenance.
- Automatically setting of optimum parameter values. With the usage selection function, users need to only select the mechanical function. Then, the device automatically sets parameters to optimum values, thereby eliminating tedious parameter setting and shortening trial run time.
- Storage of application parameters of up to 4 user groups, which is convenient for fast process switching.
- Reliable built-in parameter backup & duplicating function
- Built-in parameter change logging function
- LCD/LED keypad can be connected for long distance by remote cable.
- ES355/ES560/ES350 LED Keypad standard, LCD optional.
- ES580/ES850 LCD Keypad standard.



## Rich Application Macros

- Various built-in typical mechanical applications such as fans, water pumps, cables and unwinding and rewinding unit.
- Automatic setting of optimum parameter values.
- With the usage selection function, users need to only select the mechanical function. Then, the device automatically sets parameters to optimum values, thereby eliminating tedious parameter setting and shortening trial run time.

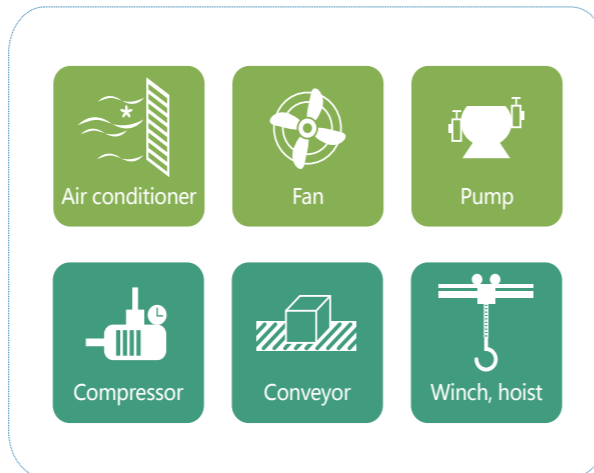

## Reliable Braking Function

- Over-excitation braking function achieves emergency braking even without brake resistor.
- The built-in braking unit is optional for the device with power of 30-90kW. The built-in braking unit is included in the standard configuration of the device with power of 22 kW and below (except ES355).
- The use of a brake resistor achieves better braking effects, saves electric installation space, and lowers electric costs for users.

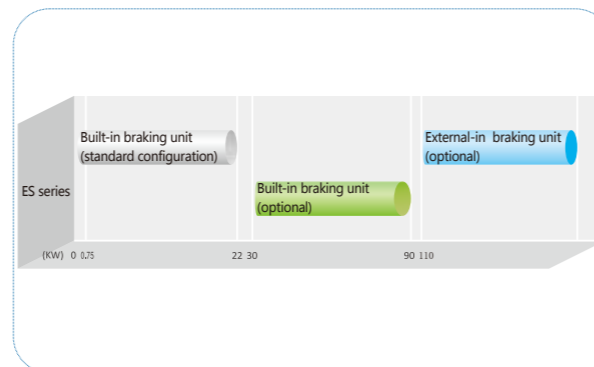

## Rich Extension Functions

- Built in RS-485 communication interface.
- Support several kinds of field bus communication protocols
- Support various PG cards.
- Support collector open encoder, differential output encoder, rotary-transformer-type encoder, and sin-cos encoder.

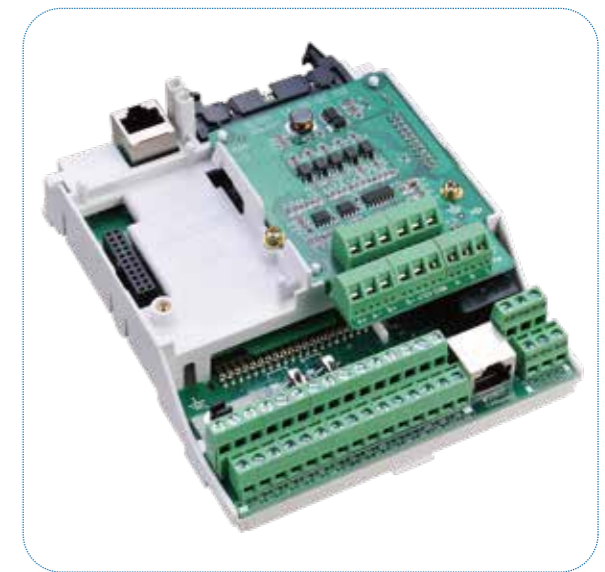

## Rich I/O Interfaces

### Type of Terminals Qty Characteristics

Digital input	7	Maximum input frequency: 1kHz, compatible with NPN and PNP input types
High-speed pulse input	1	Maximum input frequency: 50kHz, compatible with NPN and PNP input types
Analog Input	3	0~10V, 0~20mA, -10V to +10V (Optional)
Digital output	2	Maximum output frequency: 1kHz
High-speed pulse output	1	Maximum output frequency: 50kHz
Analog output	2	0~10V, 0~20mA
Relay output	2	3A/250VAC, 1A/30VDC, normally open+normally close

Note: the interfaces above are for F1 and later models. For F0 / B0 series, the quantity of some function interfaces is lower. See the technical datasheet or standard wiring diagram for details.

## Systematic and Comprehensive Protection Functions

- Frequency converter protection function: short circuit protection, overcurrent protection, overvoltage protection, under-voltage protection, input & output phase loss protection, overload protection and overheat protection.
- Motor protection function: overload protection and motor temperature protection.
- Brake circuit protection function: brake transistor overload protection, brake transistor straight-through protection, and brake resistor protection

## Compact Structure Design

- The smaller size helps save installation space, facilitate electrical layout, and is more suitable to be used in combination with the synchronous motor.
- The standard configurations uses a built-in DC reactor (F3 and above model), which helps reduce electrical installation space eliminates potential safety risks in using an external DC reactor.
- For low-power models, the rear metal plate design can effectively prevent the installation environment like oily environment from influencing the frequency converter, and guarantee secure installation.
- For medium-/high-power models, the window/cover of the rear radiator can be periodically cleaned, which is convenient for routine maintenance and cleaning of the frequency converter and saves maintenance time and costs.
- Some medium-/high-power models can be installed laterally as a blade, greatly facilitating suite design and manufacturing of professional systems.

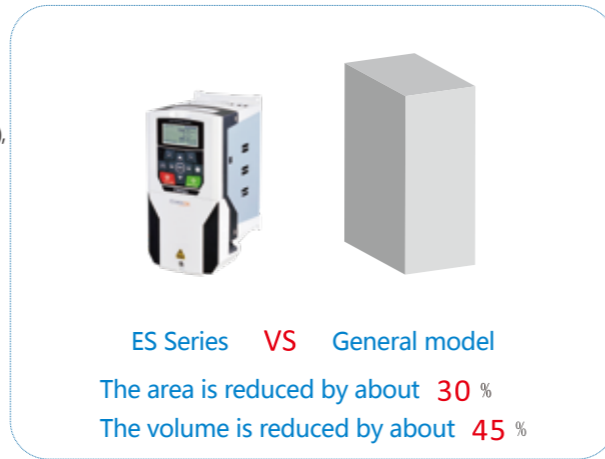

## Various Mounting Modes

- F0/B0: wall-mounted
- F1-F5: wall-mounted, flange (run-through wall) mounted optional
- F6-F9: wall-mounted, floor-mounted optional
- C10 and above floor-mounted
- B1-B5: wall-mounted
- B6-B9: wall-mounted, floor-mounted optional

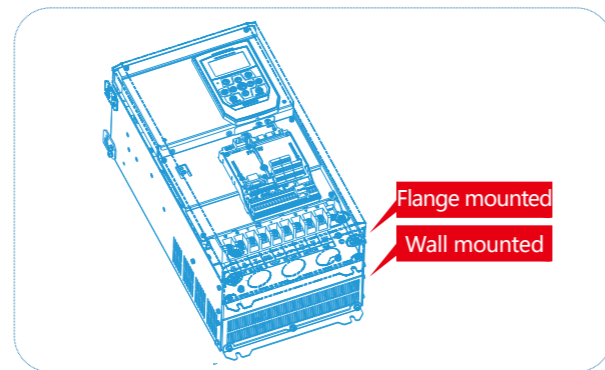

## Modular Design

- Detachable terminal block, easy for maintenance.
- The main control unit, various PG cards and communication cards adopt the modular structure design. The joints of function modules are carefully designed and easy for universal application.
- Detachable fans, easy for cleaning and replacement.
- Hot pluggable LCD keyboard.

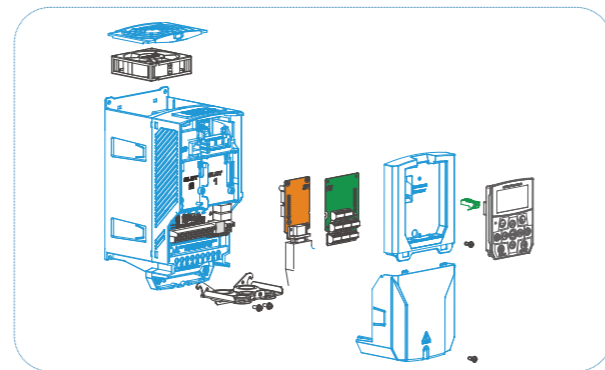

## Unique Smart Drive

- Intelligent LCD control keyboard:** The friendly human-machine interface displays key parameters relevant to running of the frequency converter and motor in real time.
- Intelligent fault diagnosis:** It records extreme operation conditions of the frequency converter, including the maximum current, voltage and maximum temperature, which are easy for fault locating and exception analysis. It also records device load conditions for customers, which are convenient for customers to optimize electric drive schemes.
- Intelligent temperature monitoring:** It detects the temperature at key points inside the machine and intelligently controls the temperature of the whole machine by using adaptive algorithms.
- Intelligent V/F curve setting:** It automatically match the most excellent performance parameters based on motor parameters, requiring no manual setting.
- Intelligent parameter setting for industry applications:** Users only need to select an industry application, and the device automatically matches optimum parameters, eliminating tedious parameter setting.

## Naming Rules

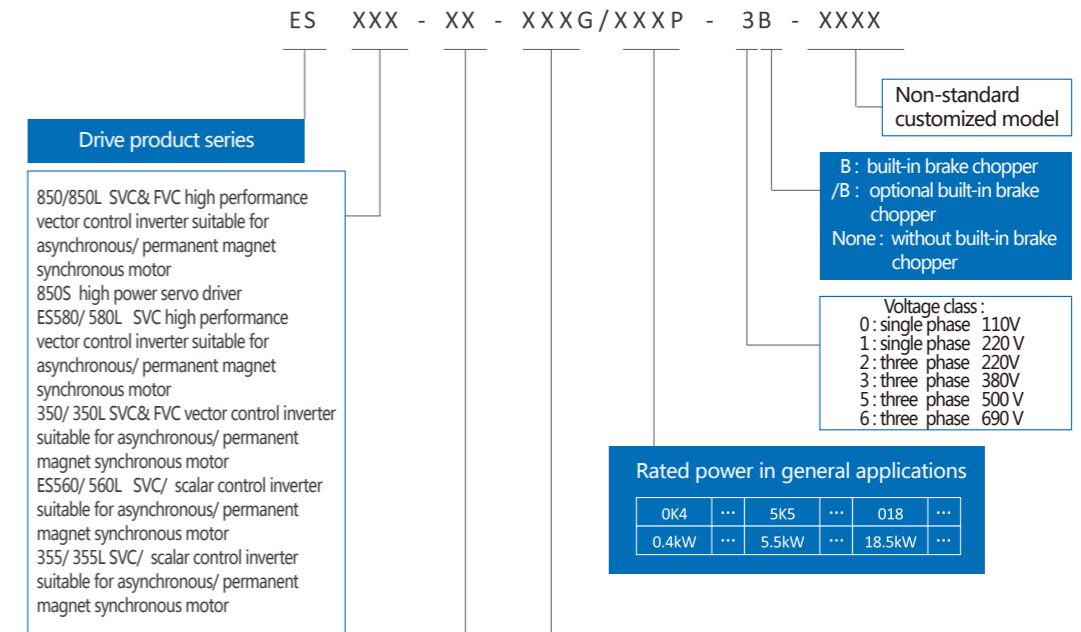

**Dimensions:**  
 01: first dimension and structure  
 02: second dimension and structure... and so on

**Rated power in heavy load applications**

0K4	...	5K5	...	018	...
0.4kW	...	5.5kW	...	18.5kW	...



ES355/355L Technical Data

Item	Specification and Technical Data	
Main power connection	Input voltage U1	1Ph ~220V±15%/3Ph ~220V±15%/3Ph ~380V±15%
	Input frequency f1	47~63Hz
	Output voltage U2	0..U1 (V) (The maximum output voltage equals the input power voltage.)
	Output frequency f2	0-1000Hz
	Carrier frequency	2-12KHz (The device can intelligently and automatically make optimal adjustment according to load characteristics and drive temperature.)
	Input voltage unbalance degree	Maximum: ±3% of rated inter-phase input voltage
	Efficiency	≈98% (when operating at ratedpower)
Basic functions	Input frequency resolution	Digital setting: 0.01Hz/RPM Analog setting: Maximum Frequency/ RPM*0.05%
	Control mode	Scalar control, SVC control
	Startup torque	100% @ 0.5Hz for V/F control, 100% @ 0.25Hz for SVC control.
	Speed adjustment range	1: 100 @ V/F control; 1: 200 @ SVC Control;
	Torque boost	Manual torque boost 0~10%
	V/F Curve	Intelligent adaptive
	V/F Separation	Full separation
	Acceleration & Deceleration curves	Straight-line/ Multi-segment/ S-curve acceleration& deceleration method, Two acceleration time and its range : 0.0s-650.00s.
	Simple PLC function	Up-to-16-stages Speed ( achieved by PLC or output terminals)
	Built-in PID	Conveniently achieve the process control via close-loop feedback system
	Automatic voltage regulation (AVR)	When the grid voltage changes, the device automatically maintains constant output voltage.
	Automatic acceleration & deceleration function	Automatic extend the acceleration/deceleration time to avoid frequent overvoltage/overcurrent fault.
	Protection function	Output short circuit protection, input and output phase loss protection, overcurrent protection, overvoltage protection, undervoltage protection, overheat protection, overload protection, safe torque stop and other protection functions ect.
	STO safe torque stop function	When the equipment is overhauled, ensure that the equipment stops reliably.
	Non-stop during transient interruption	Keep the frequency inverter running in a short time during the sudden power failure (In case of instantaneous power failure, the load will feed back energy to compensate for the voltage drop).
	Flux brake	Can realize fast stop without braking resistor
	Synchronous stop after power failure	When the power grid is unexpectedly cut off, it can ensure that multiple inverters are steadily and synchronously stopped.
	Fieldbus communication	Built-in standard Modbus interface, self-defining simple CAN communication is optional.

Item	Specification and Technical Data	
I/O Interfaces	Command input mode	Keyboard input, Control terminals input, Field bus communication input
	Speed reference mode	Digital, Analog (AO terminals & Built-in potentiometer ), Pulse , Fieldbus communication , and PID .
I/O Interfaces	Input terminal	The followings are included in standard configuration : - 4 digital input terminals( suport PNP and NPN, among DI4 support 60kHz High-speed pulse) - 1 analog input terminal( 0~+10V/4~20mA), - 2 STO function terminals.
	Output terminal	The followings are included in standard configuration : - 1 digital output DO1, support 60kHz hig-speed pulse & 0~50Hz squarewave pulse. - 1 analog output terminal( 0~+10V/4~20mA), - 1 relay output terminal, NO/NC selection.
Display and control	Man-machine interface	Standard fixed LED keyboard, support external detachable large-screen LCD or LED keyboard.
	Parameters duplicating	Rapidly duplicating parameters via the LCD control keyboard
Application environment	Application site	Indoor, free of direct sunshine, dusts, corrosive gases, flammable gases, oil mist, water vapor, drip or salts
	Altitude	0-1000m ; When the altitude is 1000-4000m, the capacity is reduced by 1% as the altitude rises by 100m. (consult professionals for more accurate values)
	Operation ambient Temperature	-10℃ ~ +55℃ when the ambient temperature is 40℃-55℃, the driveis automatically derated to achieve self-protection)
	Relative humidity	Less than 95%RH. No droplets condensed (condensation)
	sinusoidal vibration	(IEC 60068- 2/-6.TestFc) Max.0.1mm (5 to 13.2Hz) ; max.7m/ s <sup>2</sup> (13.2 to 100 Hz) Max.0.1mm (10 to 57Hz) ; max.10m/ s <sup>2</sup> (57 to 150Hz)
	Impact	Not allowed (during operation); maximum 100m/s <sup>2</sup> ,11ms(during storage and transportation with packing)
	Free fall (Max.)	Not allowed (during operation); with packing : 100cm @F0-2,76cm @F0-4,46cm @F5-7,15cm @F8-9
	Storage & temperature	-40℃ to+70℃
Protection grade	IP20	
Cooling method	The air flows from bottom to top. Air-cooled radiator.	
Application standard	IEC 61800-3 (2004), IEC61800-5-1 (2007) ; GB12668	

ES560/560L Technical Data

Item	Specification and Technical Data	
Item	Input voltage U1	380V~460V±15%
	Input frequency f1	50...60Hz ±5%
	Output voltage U2	0...U1 (V) (The maximum output voltage equals the input power voltage.)
	Output frequency f2	0-1000Hz
	Carrier frequency	2-8 KHz (The device can intelligently and automatically make optimal adjustment according to load characteristics and drive temperature.) Consult factory for higher carrier frequency.
	Input voltage unbalance degree	Maximum: ±3% of rated inter-phase input voltage
	Efficiency	≈98% (when operating at rated power)
	Resolution of given speed	Digital setting: 1 RPM / 0.01Hz      Analog setting: 0.025% of maximum RPM
	Control Mode	SVC control, scalar control
	Basic functions	Startup Torque
Speed Adjustment Range		1 : 200 @ SVC vector control
Overload capacity		Heavy load application: 60s at 150% rated current @40°C.The time depends on the drive temperature under other conditions. Light load application: 60s at 120% rated current @40°C. The time depends on the drivetemperature under other conditions.
Torque boost		Manual torque boost 1%-10%
V/F curve		Intelligent adaptive
V/ F Separation		Completely separated
Acceleration and Deceleration curves		straight-line or S-curve acceleration and deceleration mode Two acceleration time values. The acceleration and deceleration time range : 0.0s-650.00s
Simple PLC function		Achieve operation of up-to-16-stages speed (via built-in PLC or control terminals)
Built-in PID		Conveniently achieve the process control close-loop control system
Automatic voltage		When the grid voltage changes, the device automatically maintains constant output voltage.
Overvoltage and overcurrent stall control		The current and voltage are automatically limited during running to avoid jump faults due to frequent overcurrent and overvoltage
Protection function		Output shortcircuit protection, input & output phase loss protection, overcurrent protection, overvoltage protection, undervoltage protection, overheat protection, overload protection, brake chopper overload protection, brake chopper shortcircuit protection, brake resistor overload protection
Non-stop during transient interruption		When a short-term power failure occurs in the power grid, the drive will run at a reduced speed. After the power grid is on, the drive will back to normal working status..
Timing control		Timing control function. The time range and precision is 0.0-6500.0(min).
Power failure		In the case of unexpected power failure, the inverter can be guaranteed to stop steadily
Communication Bus		Standard built-in Modbus, can be extended to CANopen, Profibus-DP, Profinet, EtherCAT bus communication

Item	Specification and Technical Data	
I/O Input Output Interface	Command input mode	Control keyboard input, control terminal input, bus communication input, which can be switched mutually.
	Speed reference mode	Digital giving, analog voltage (current) giving, pulse giving, bus communication giving and PID giving, which are mutually switched.
I/O Input Output Interface	Input terminals	The followings are included in standard configuration: 7 digital input terminals, where DI7 supports the maximum of 50 kHz high-speed pulse input. 3 analog input terminals (where, at least 2 supports 0-10V voltage or 0-20mA).
	Output terminals	The followings are included in standard configuration: 1 high-speed pulse output terminal (supporting 0-50 kHz square signal output); 2 digital output terminals; 2 relays output terminals; 2 analog output terminals (supporting 0~10V output or 0~20mA).
Display	Man-machine interface	Removable LED keypad as standard configuration, LCD keypad is optional.
	Parameters Duplication	Rapidly duplicating parameters via the LCD control keyboard
Application environment	Application site	Indoor, free of direct sunshine, dusts, corrosive gases, flammable gases, oil mist,
	Altitude	When the altitude is 0~1000m or 1000~4000m, the capacity is reduced by 1% as the altitude rises by 100m. (consult professionals for more accurate values)
	Operation ambient temperature	-10°C to+40°C (when the ambient temperature is 40°C-55°C, the drive is automatically derated to achieve self-protection)
	Relative humidity	Less than 95%RH. No droplets condensed (condensation)
	Sinusoidal vibration	(IEC 60068- 2/ - 6.TestFc) Max.0.1mm (5 to 13.2Hz) ; max.7m/S 2 (13.2 to 100 Hz) sinusoidal vibration (F1-B7) Max.0.1mm (10 to 57Hz) ; max.10m/S2 (57 to 150 Hz) sinusoidal vibration (B8-B9)
	Impact	Not allowed (during operation); maximum 100m/S 2 , 11ms (during storage and transportation with packing)
	Free fall (Max.)	Not allowed (during operation); with packing : 100cm@F1,F2,F2A ; 76cm @F3,B4, 46cm@B8-B9
Storage & transportation temperature	-40°C to+70°C (-40to+158°F)	
Protection grade	Electrical cavity full closed design for small- and medium-power models,	
Cooling mode	Forced air cooling of the interior fan. The air flows from bottom to top. Air-cooled radiator.	
Application standard	IEC 61800-3(2004);IEC 61800-5-1(2007);GB 12668	

(ES350/350L)-(ES580/580L)-(ES850/850L) Technical Data

Item	Specification and Technical Data		
Main power connection	Input voltage U1	220V/380V/500/690V±15% ;signal/three-phase power	
	Input frequency f1	50...60Hz ±5Hz	
	Output voltage U2	0..U1 (V)(The maximum output voltage equals the input power voltage.)	
	Output frequency f2	0-1000Hz	
	Carrier frequency	2-8 KHz (The device can intelligently and automatically make optimal adjustment according to load characteristics and drive temperature.)	
	Input voltage unbalance degree	Maximum: ±3% of rated inter-phase input voltage	
	Efficiency	≈ 98% (when operating at rated power)	
Basic functions	Speed range	0-1000Hz ( 0~30000 rpm, 60000rpm is optional )	
	Resolution of given speed	Digital setting: 1RPM Analog setting: 0.025% of maximum RPM	
	Control mode	SVC control / FVC vector control	
	Starting speed	200% @ 0.25Hz@ SVC control 200% @0Hz@ FVC control	
	Speed ratio	1 : 200 @ SVC control 1 : 3000 @ FVC control	
	Steady-speed precision	±0.5% @ SVC control ±0.01% @ FVC control	
	Overload capacity	Heavy load application: 60s at 150% rated current @40°C. The time depends on the drive temperature under other conditions. General application: 60s at 120% rated current @40°C. The time depends on the drivetemperature under other conditions.	
	Torque boost	Automatic torque boost. Manual torque boost 0.1%-30%	
	Acceleration and deceleration curves	straight-line or S-curve acceleration and deceleration mode Two acceleration time values. The acceleration and deceleration time range : 0.0s-650.00s	
	Simple PLCfunction	Achieve operationof up-to-16-stages speed(via built-in PLC or control terminals)	
	Built-in PID	Conveniently achieve the process control close-loop control system	
	Automatic voltage regulation (AVR)	When the grid voltage changes, the device automatically maintainsconstant output voltage.	
	Overvoltage and overcurrent stall control	The current and voltage are automatically limited during running to avoid jump faults due to frequent overcurrent and overvoltage	
	Enhancements	Torque limiting and control	The torque is automatically limited operating (to avoid frequent overcurrent jumping fault due to too large torque).
		Protection function	Output shortcircuit protection, input & output phase loss protection, overcurrent protection, overvoltage protection, undervoltage protection, overheat protection, overload protection, brake chopper overload protection, brake chopper shortcircuit protection, brake resistor overload protection
Non-stop during transient interruption		Keep the frequency converteroperating in a short time (by reducing feedback energy compensation voltageat the moment of power outage). The duration depends on the mechanical inertia of the load at that time.	
Speed tracking restart		Asynchronous motor speed tracking start can be realized ( standard ) and synchronous motor speed tracking start ( optional)	
Timing control		Timing control function. The time range and precision is 0.0-6500.0(min).	
Switching multiple motors		Support switching among four groups of motor parameters.	
Bus communication		The standard configuration uses the built-in Modbus/communication, which can be extended to Profibus-DP , CANopen bus communication. Etc.	
Intelligent temperature control		Full cover system temperature testing, intelligent real-time IGBT chip temperature monitoring, and intelligent and optimized adjustment of the carrier and current based on drive temperature changes	
Type of encoders supported		Support differential encoders, collector open encoders, rotary transformer encoders , and Sin-Cos Encoders	
Communication linkage synchronization		Easily realize multi-motor synchronous transmission, and can freely choose to realize the linkage balance of multi-motor by current, torque or power.	
Debug window		Visual parameter debugging, fault display and waveform monitoring can be easily realized through the PC terminal etc.	

Item	Specification and Technical Data	
I/O Input Output Interface	Command input mode	Control keyboard input, control terminal input, bus communication input, which can be switched mutually.
	Speed reference mode	Digital giving, analog voltage (current) giving, pulse giving, bus communication giving and PID giving, which are mutually switched.
I/O Input Output Interface	Input terminal (input)	The followings are included in standard configuration : 6 (F0) / 7 (F1 and above) digital input terminals, where, DI6 (F0) DI7 (F1 and above)supports the maximum of 50 kHz high-speed pulse input. 2 (F0) /3 (F1 and above) analog input terminals (where, at least 2 supports 0-10V voltage input or 0-20 mA or 4-20mA voltage input) The followings are extended as cards : 5 digital input terminals 2 analog input terminals, supporting input of -10V to+10V voltage (Optional)
	Output terminal (output)	The followings are included in standard configuration: 1 high-speed pulse output terminal (supporting 0-50 kHz square signal output ) 1 (F0) /2 (F1 and above) digital output terminals 1 (F0) /2 (F1 and above) relay output terminals 1 (F0) /2 (F1 and above) analog output terminals (supporting0-10V voltage output or 0- 20mA or 4-20 mA voltage output)
Display and control	Man-machine interface	F0 built in fixed LED keypad, and LCD keypad is optional. F1 and above is built in standard smart LCD keyboard, LED keypad is optional
	Parameters duplicating	Rapidly duplicating parameters via the LCD control keyboard
Application environment	Application site	Indoor, free of direct sunshine, dusts, corrosive gases, flammable gases, oil mist, water vapor, drip or salts
	Altitude	At 0-1000m ; When the altitude is 1000-4000m, the capacity is reduced by 1% as the altitude rises by 100m. (consult professionals for more accurate values)
	Operation ambient temperature	-10°C to+40°C (when the ambient temperature is 40°C-55°C, the drive is automatically derated to achieve self-protection)
	Relative humidity	Less than 95%RH. No droplets condensed (condensation)
	Sinusoidal vibration	(IEC 60068- 2/ - 6.TestFc) Max.0.1mm (5 to 13.2Hz) ; max.7m/S <sup>2</sup> (13.2 to 100 Hz) sinusoidal vibration (F0-F7) Max.0.1mm (10 to 57Hz) ; max.10m/S <sup>2</sup> (57 to 150 Hz) sinusoidal vibration (F8-F9)
	Impact	Not allowed (during operation); maximum 100m/S <sup>2</sup> , 11ms (during storage and transportation with packing)
	Free fall (Max.)	Not allowed (during operation); with packing : 100cm @F0-F2A, 76cm @F3-F4, 46cm @F5-F7, 15cm @F8-F9
Storage & transportation temperature	-40°C to+70°C (-40 to +158°F)	
Protection grade	IP20 (UL-open type), (the medium cavity with air vents on two sides for some F0** models) Electrical cavity full closed design for small- and medium-power models, Top/Left and right sides can reach IP40	
Cooling mode	Forced air cooling of the interior fan. The air flows from bottom to top. Air-cooled radiator.	
Application standard	IEC 61800-3 , IEC 61800-5-1 ; GB12668 (see the nameplate for details).	

ES850S Technical Data

Item	Specification and Technical Data	
Main power connection	Input voltage U1	220V/380V/500/690V±15%;signal/three-phase power
	Input frequency f1	50..60Hz ±5Hz
	Output voltage U2	0..U1 (V)(The maximum output voltage equals the input power voltage.)
	Output frequency f2	0-1500Hz
	Carrier frequency	2-8 KHz (The device can intelligently and automatically make optimal adjustment according to load characteristics and drive temperature.)
	Input voltage unbalance degree	Maximum: ±3% of rated inter-phase input voltage
	Efficiency	≈ 98% (when operating at rated power)
Basic functions	Speed range	0-1000Hz ( 0~30000 rpm, 60000rpm is optional )
	Resolution of given speed	Digital setting: 1RPM Analog setting: 0.025% of maximum RPM
	Control mode	SVC control / FVC control
	Starting speed	200% @ 0.25Hz@ SVC control 200% @0Hz@ FVC control
	Speed ratio	1 : 200 @ SVC control 1 : 3000 @ FVC control
	Steady-speed precision	±0.5% @ SVC control ±0.01% @ FVC control
	Overload capacity	Heavy load application: 60s at 150% rated current @40°C. The time depends on the drive temperature under other conditions. General application: 60s at 120% rated current @40°C. The time depends on the drivetemperature under other conditions.
	Torque boost	Automatic torque boost. Manual torque boost 0.1%-30%
	Acceleration and deceleration curves	straight-line or S-curve acceleration and deceleration mode Two acceleration time values. The acceleration and deceleration time range : 0.0s-650.00s
	Simple PLCfunction	Achieve operationof up-to-16-stages speed(via built-in PLC or control terminals)
	Built-in PID	Conveniently achieve the process control close-loop control system
	Automatic voltage regulation (AVR)	When the grid voltage changes, the device automatically maintainsconstant output voltage.
	Motor temperature protection	Support PTC, PT100, KTY84 temperature sensor input
	Overvoltage and overcurrent stall control	The current and voltage are automatically limited during running to avoid jump faults due to frequent overcurrent and overvoltage
Enhancements	Torque limiting and control	The torque is automatically limited operating (to avoid frequent overcurrent jumping fault due to too large torque).
	Protection function	Output shortcircuit protection, input & output phase loss protection, overcurrent protection, overvoltage protection, undervoltage protection, overheat protection, overload protection, brake chopper overload protection, brake chopper shortcircuit protection, brake resistor overload protection
	Non-stop during transient interruption	Keep the frequency converteroperating in a short time (by reducing feedback energy compensation voltageat the moment of power outage). The duration depends on the mechanical inertia of the load at that time.
	Speed tracking restart	Asynchronous motor speed tracking start can be realized ( standard ) and synchronous motor speed tracking start ( optional)
	Timing control	Timing control function. The time range and precision is 0.0-6500.0(min).
	Switching multiple motors	Support switching among four groups of motor parameters.
	Bus communication	Built-in Modbus, with Profibus-DP, Canopen, Profinet, EtherCat and other Fildbus communication optional
	Intelligent temperature control	Full cover system temperature testing, intelligent real-time IGBT chip temperature monitoring, and intelligent and optimized adjustment of the carrier and current based on drive temperature changes
	Type of encoders supported	Support differential encoders, collector open encoders, rotary transformer encoders , and Sin-Cos Encoders
	Positioning Function	Support any angle positioning from 0 to 360°
	Communication linkage synchronization	Easily realize multi-motor synchronous transmission, and can freely choose to realize the linkage balance of multi-motor by current, torque or power.
	Debug window	Visual parameter debugging, fault display and waveform monitoring can be easily realized through the PC terminal etc.

Item	Specification and Technical Data	
I/O Input Output Interface	Command input mode	Control keyboard input, control terminal input, bus communication input, which can be switched mutually.
	Speed reference mode	Digital giving, analog voltage (current) giving, pulse giving, bus communication giving and PID giving, which are mutually switched.
I/O Input Output Interface	Input terminal (input)	7 (F1 and above) digital input terminals, Among them, DI7 (F1 and above) supports high-speed pulse input up to 50KHz, 3 (F1 and above) analog input terminals (DI1 DI2 support signal 0-10V/ 0-20mA/ 4- 20mA)
	Output terminal (output)	1 high-speed pulse output terminal (supports 0-50KHz square wave signal output) 2 (F1 and above) digital output terminals, 2 (F1 and above) relay output terminals, 2 (F1 and above) analog output terminals(support 0-10V/0-20mA/4~20mA)
Display and control	Man-machine interface	F1 and above is built in standard smart LCD keyboard, LED keypad is optional
	Parameters duplicating	Rapidly duplicating parameters via the LCD control keyboard
Application environment	Application site	Indoor, free of direct sunshine, dusts, corrosive gases, flammable gases, oil mist, water vapor, drip or salts
	Altitude	At 0-1000m ; When the altitude is 1000-4000m, the capacity is reduced by 1% as the altitude rises by 100m. (consult professionals for more accurate values)
	Operation ambient temperature	-10°C to +40°C (when the ambient temperature is 40°C-55°C, the drive is automatically derated to achieve self-protection)
	Relative humidity	Less than 95%RH. No droplets condensed (condensation)
	Sinusoidal vibration	(IEC 60068- 2/ - 6.TestFc) Max.0.1mm (5 to 13.2Hz) ; max.7m/S <sup>2</sup> (13.2 to 100 Hz) sinusoidal vibration (F0-F7) Max.0.1mm (10 to 57Hz) ; max.10m/S <sup>2</sup> (57 to 150 Hz) sinusoidal vibration (F8-F9)
	Impact	Not allowed (during operation); maximum 100m/S <sub>2</sub> , 11ms (during storage and transportation with packing)
	Free fall (Max.)	Not allowed (during operation); with packing : 100cm @F0-F2A, 76cm @F3-F4, 46cm @F5-F7, 15cm @F8-F9
	Storage & transportation temperature	-40°C to +70°C (-40 to +158°F)
Protection grade	IP20 (UL-open type), (the medium cavity with air vents on two sides for some F0** models) Electrical cavity full closed design for small- and medium-power models, Top/Left and right sides can reach IP40	
Cooling mode	Forced air cooling of the interior fan. The air flows from bottom to top. Air-cooled radiator.	
Application standard	IEC 61800-3 , IEC 61800-5-1 ; GB12668 (see the nameplate for details).	

### Selection of ES355/355L Products

- 1) Standard configuration STO safety torque off function
- 2) Support SVC/ scalar control
- 3) Support permanent magnet synchronous motor/asynchronous motor control
- 4) Standard C3 filter
- 5) Large screen LCD or LED keyboard can be connected externally
- 6) All DI terminals both support PNP & NPN input, DI4 supports 60kHz high-speed input
- 7) Standard configuration of magnetic flux braking function
- 8) The carrier frequency can be adjusted intelligently according to the temperature



#### Rated voltage 1ph 220V (adapted to working voltage range 220±15 %)

Model Code	Rated Value	Rated Power	Power loss	Noise Level	Air Volume	Dimension
	( A )	( kW )	( W )	( dB )	( m3/h )	
ES355/355L-B0-0K4G-1	2.5	0.4	40	*	*	B0
ES355/355L-B0-0K7G-1	4.5	0.75	65	36	30.6	
ES355/355L-B0-1K5G-1	7	1.5	80	36	30.6	
ES355/355L-B0-2K2G-1	9	2.2	92	36	30.6	

Note: (1) \* indicates no fan product, relying on natural air cooling, close to silent;  
 (2) Power rating is measured at rated voltage 220V.

#### Rated voltage 3ph 220V (adapted to working voltage range 220±15 %)

Model Code	Rated Value	Rated Power	Power loss	Noise Level	Air Volume	Dimension
	( A )	( kW )	( W )	( dB )	( m3/h )	
ES355/355L-B0-0K4G-2	2.5	0.4	40	*	*	B0
ES355/355L-B0-0K7G-2	4	0.75	76	36	30.6	
ES355/355L-B0-1K5G-2	5	1.5	97	36	30.6	
ES355/355L-B0-2K2G-2	8	2.2	125	36	30.6	

Note: (1) \* indicates no fan product, relying on natural air cooling, close to silent;  
 (2) Power rating is measured at rated voltage 220V.

#### Rated voltage 3ph 380V (adapted to working voltage range 380±15 %)

Model Code	Rated Value	Rated Power	Power loss	Noise Level	Air Volume	Dimension
	( A )	( kW )	( W )	( dB )	( m3/h )	
ES355/355L-B0-0K7G-3	2.5	0.75	40	*	*	B0
ES355/355L-B0-1K5G-3	4	1.5	76	36	30.6	
ES355/355L-B0-2K2G-3	5	2.2	97	36	30.6	
ES355/355L-B0-4K0G-3	8	4.0	125	36	30.6	

Note: (1) \* indicates no fan product, relying on natural air cooling, close to silent;  
 (2) Power rating is measured at rated voltage 380V.

### Selection of ES560/560L Products

- 1) High reliability
- 2) Easy operation
- 3) Support SVC/ scalar control
- 4) Compatible permanent magnet synchronization & 3phase asynchronous motor
- 5) Built in digital LED keyboard optional Intelligent LCD display
- 6) Modular compact structure design



#### 380V 3ph rated voltage( adapt to the working voltage range 380~460V ±15% )

Model Code	Rated Value		Heavy Load Application		Noise Level	Heat Radiation	Air Volume	Shell code
	I <sub>Ld</sub> (A)	P <sub>Ld</sub> (kW)	I <sub>Hd</sub> (A)	P <sub>Hd</sub> (kW)	dBA	W	m <sup>3</sup> /h	
ES560/560L-01-5K5G/7K5P-3B	17.5	7.5	14.5	5.5	55	210	130	B1
ES560/560L-02-7K5G/011P-3B	25	11	17.6	7.5	55	325	130	B2
ES560/560L-02-011G-3B	/	/	25	11	55	420	130	
ES560/560L-02A-011G/015P-3B	35	15	25	11	52	470	175	B2A
ES560/560L-02A-015G/018P-3B	38.6	18.5	35	15	52	550	175	
ES560/560L-03-018G/022P-3B	46	22	41	18.5	57	660	306	B3
ES560/560L-03-022G/030P-3B	61	30	48	22	57	890	306	
ES560/560L-04-030G/037P-3/B	75	37	66	30	60	1114	610	B4
ES560/560L-04-037G/045P-3/B	91	45	79	37	60	1140	610	
ES560/560L-04-045G/055P-3/B	115	55	94	45	60	1200	610	
ES560/560L-05-055G/075P-3/B	155	75	116	55	60	1440	610	B5
ES560/560L-05-075G/090P-3/B	178	90	160	75	60	1940	610	
ES560/560L-05-090G/110P-3/B	215	115	179	90	68	2200	850	
ES560/560L-06-110G/132P-3	261	132	215	110	68	3300	1275	B6
ES560/560L-06-132G/160P-3	310	160	259	132	68	3850	1275	
ES560/560L-07-160G/200P-3	387	200	314	160	75	4100	1800	B7
ES560/560L-07-200G/220P-3	427	220	387	200	75	4600	1800	
ES560/560L-07-220G/250P-3	450	250	427	220	75	5100	1800	
ES560/560L-08-250G/280P-3	525	280	481	250	72	5782	2190	B8
ES560/560L-08-280G/315P-3	600	315	550	280	72	6252	2190	
ES560/560L-08-315G/355P-3	660	355	616	315	72	7866	2190	
ES560/560L-09-355G/400P-3	720	400	650	355	75	9100	2700	B9
ES560/560L-09-400G/450P-3	810	450	720	400	75	9900	2700	
ES560/560L-09-450G/500P-3	870	500	810	450	75	10500	2700	
ES560/560L-09-500G/560P-3	980	560	870	500	75	11500	2700	
ES560/560L-09-560G/630P-3	1060	630	980	560	75	12600	2700	

Note: Rated power is measured under rated voltage 380V

G- constant torque load application, P-square torque load application, - indicate that the item is not supported. Rated value

I<sub>N</sub> Continuous and available rated current without load at 40 °C

I<sub>max</sub> Maximum output current. Ten seconds are allowable at startup. Under other circumstances, the time depends on temperature

General load application:

I<sub>Ld</sub> Continuous rated output current of P converter s at ≤ 40 °C. The overload current value is allowed to reach 120% of

I<sub>LD</sub> in 1 minute out of every five minutes. The time depends on the drive temperature under other circumstances.

P<sub>Ld</sub> Typical motor power in the light load application.

Heavy load application:

I<sub>Hd</sub> Continuous rated output current of G converters at ≤ 40 °C. The overload current value is allowed to reach 150% of

I<sub>HD</sub> in 1 minute out of every five minutes. The time depends on the drive temperature under other circumstances.

P<sub>HD</sub> Typical motor power in the heavy load application.

### Selection of ES350/350L Products

- 1) Small size and compact
- 2) Easy commissioning, optional intelligent LCD keyboard
- 3) Support SVC/ FVC vector control
- 4) Support permanent magnet synchronous motor/asynchronous motor control
- 5) Smart PID function
- 6) With 6 digital input terminals
- 7) Support both speed & torque control



### 220V 3ph rated voltage( adapt to the working voltage range 208~240V ±15% )

Model Code	Rated Value		General Load Application		Heavy Load Application		Noise Level	Heat Radiation	Air Volume	Dimension
	I <sub>N</sub> (A)	I <sub>max</sub> (A)	I <sub>Ld</sub> (A)	P <sub>Ld</sub> (kW)	I <sub>Hd</sub> (A)	P <sub>Hd</sub> (kW)				
ES350-F0-0K4G/0K7P-2B	5.2	6	4.5	0.75	2.5	0.37	40	40	25	F0* <sup>3)</sup>
ES350-F0-0K7G/1K5P-2B	6.3	7.5	7	1.5	4.5	0.75	40	65	25	
ES350-F0-1K5G/2K2P-2B	9.5	11	8.5	2.2	7	1.5	40	80	25	
ES350-F0-2K2G-2B	10	12	\	\	9	2.2	40	92	25	F0** <sup>3)</sup>

Note: Rated power is measured under rated voltage 220V

### 220V 1ph rated voltage( adapt to the working voltage range 208~240V ±15% )

Model Code	Rated Value		General Load Application		Heavy Load Application		Noise Level	Heat Radiation	Air Volume	Dimension
	I <sub>N</sub> (A)	I <sub>max</sub> (A)	I <sub>Ld</sub> (A)	P <sub>Ld</sub> (kW)	I <sub>Hd</sub> (A)	P <sub>Hd</sub> (kW)				
ES350-F0-0K4G/0K7P-1B	4.8	6	4.5	0.75	2.5	0.37	40	40	25	F0* <sup>3)</sup>
ES350-F0-0K7G/1K5P-1B	7.5	10	7	1.5	4.5	0.75	40	65	25	
ES350-F0-1K5G/2K2P-1B	9	11.5	8.5	2.2	7	1.5	40	80	25	
ES350-F0-2K2G-1B	10	12	\	\	9	2.2	40	92	25	

Note: Rated power is measured under rated voltage 220V

### 380V 3ph rated voltage( adapt to the working voltage range 380~460V ±15% )

Model Code	Rated Value		General Load Application		Heavy Load Application		Noise Level	Heat Radiation	Air Volume	Dimension
	I <sub>N</sub> (A)	I <sub>max</sub> (A)	I <sub>Ld</sub> (A)	P <sub>Ld</sub> (kW)	I <sub>Hd</sub> (A)	P <sub>Hd</sub> (kW)				
ES350-F0-0K7G/1K5P-3B	5.2	6	5	1.5	2.5	0.75	40	40	25	F0* <sup>3)</sup>
ES350-F0-1K5G/2K2P-3B	6.3	7.5	6	2.2	4	1.5	40	76	25	
ES350-F0-2K2G/4K0P-3B	9.5	11	9	4	5	2.2	40	97	25	
ES350-F0-4K0G-3B	10	12	\	\	8	4	40	125	25	F0** <sup>3)</sup>

Note: Rated power is measured under rated voltage 380V

G- constant torque load application, P-square torque load application, - indicate that the item is not supported. Rated value  
 I<sub>N</sub> Continuous and available rated current without load at 40 °C  
 I<sub>max</sub> Maximum output current..Ten seconds are allowable at startup. Under other circumstances, the time depends on temperature

General load application:  
 ILD Continuous rated output current of P converter s at ≤ 40 °C. The overload current value is allowed to reach 120%of  
 ILD in 1 minute out of every five minutes. The time depends on the drive temperature under other circumstances.  
 PLD Typical motor power in the light load application.

Heavy load application:  
 IHD Continuous rated output current of G converters at ≤ 40 °C. The overload current value is allowed to reach 150%of  
 IHD in 1 minute out of every five minutes. The time depends on the drive temperature under other circumstances.  
 PHD Typical motor power in the heavy load application.

1)=110V, 115v series models need to be consulted to confirm inventory and supply cycle  
 2)=Contains 6 vein or 12 pulse rectifier power circuit, the specific order before please consult our company representative.  
 3)=\* represent independent closed air duct structure, \*\* represent independent closed air duct with cooling hole structure,  
 - represent this item not supported.  
 4)=Manufacturers need to consult before ordering

### Selection of ES580/580L Products

- 1) High reliability
- 2) precision control
- 3) Intelligent LCD keyboard included in standard configuration
- 4) Modular compact structure design
- 5) Support SVC vector control
- 6) Support permanent magnet synchronous motor/asynchronous motor control
- 7) Support several kinds of field bus communication protocols (PROFIBUS-DP, CANopen, Profinet, EtherCAT)
- 8) Built-in logic arithmetic function



### 220V 3ph rated voltage( adapt to the working voltage range 208~240V ±15%)

Model Code	Rated Value		General Load Application		Heavy Load Application		Noise Level	Heat Radiation	Air Volume	Dimension
	I <sub>N</sub> (A)	I <sub>max</sub> (A)	I <sub>Ld</sub> (A)	P <sub>Ld</sub> (kW)	I <sub>Hd</sub> (A)	P <sub>Hd</sub> (kW)				
ES580-01-0K4G/0K7P-2B	5.2	7	5	0.75	2.5	0.37	45	40	89	F1
ES580-01-0K7G/1K5P-2B	6.3	9	6	1.5	4.2	0.75	45	76	89	
ES580-01-1K5G/2K2P-2B	10.5	15	9.8	2.2	5.6	1.5	45	97	89	
ES580-01-2K2G/4K0P-2B	18.2	25	17.5	4	14.5	2.2	45	172	130	F2
ES580-02-4K0G/5K5P-2B	26	36	25	5.5	17.6	4	45	325	130	
ES580-02-5K5G-2B	28	35	\	\	25	5.5	45	420	130	F2A
ES580-02A-5K5G/7K5P-2B	37	50	35	7.5	25	5.5	52	470	175	
ES580-02A-7K5G/011P-2B	41	57	38.6	11	35	7.5	52	550	175	F3
ES580-03-7K5G/011P-2B	41	57	38.6	11	35	7.5	57	550	306	
ES580-03-011G/015P-2B	63.5	89	61	15	48	11	57	890	306	F4
ES580-04-015G/018P-2	78	109	75	18.5	66	15	60	1114	610	
ES580-04-018G/022P-2	95	133	91	22	79	18.5	60	1140	610	F5
ES580-04-022G/030P-2	120	168	115	30	94	22	60	1200	610	
ES580-05-030G/037P-2	162	227	155	37	116	30	60	1440	610	F5
ES580-05-037G/045P-2	185	222	178	45	160	37	60	1940	610	
ES580-05-045G/055P-2	225	270	215	55	179	45	67	2200	850	F6
ES580-06-055G/075P-2	272	326	261	75	215	55	68	3300	1275	

Note: Rated power is measured under rated voltage 220V

### 380V 3ph rated voltage ( adapt to the working voltage range 380~460V ±15% )

Model Code	Rated Value		General Load Application		Heavy Load Application		Noise Level	Heat Radiation	Air Volume	Dimension
	I <sub>N</sub> (A)	I <sub>max</sub> (A)	I <sub>Ld</sub> (A)	P <sub>Ld</sub> (kW)	I <sub>Hd</sub> (A)	P <sub>Hd</sub> (kW)				
ES580/580L-01-0K7G/1K5P-3B	5.2	7	5	1.5	2.5	0.75	45	40	89	F1
ES580/580L-01-1K5G/2K2P-3B	6.3	9	6	2.2	4.2	1.5	45	76	89	
ES580/580L-01-2K2G/4K0P-3B	10.5	15	9.8	4	5.6	2.2	45	97	89	
ES580/580L-01-4K0G/5K5P-3B	14	20	13.5	5.5	10.5	4	45	172	89	F2
ES580/580L-01-5K5G/7K5P-3B	18.2	25	17.5	7.5	14.5	5.5	45	210	130	
ES580/580L-02-7K5G/011P-3B	26	36	25	11	17.6	7.5	45	325	130	F2A
ES580/580L-02-011G-3B	28	35	26	15	25	11	45	420	130	
ES580/580L-02A-011G/015P-3B	37	50	35	15	25	11	52	470	175	F3
ES580/580L-02A-015G/018P-3B	41	57	38.6	18.5	35	15	52	550	175	
ES580/580L-03-015G/018P-3B	41	57	38.6	18.5	35	15	57	550	306	F4
ES580/580L-03-018G/022P-3B	48	67	46	22	41	18.5	57	660	306	
ES580/580L-03-022G/030P-3B	63.5	89	61	30	48	22	57	890	306	F5
ES580/580L-04-030G/037P-3/B	78	109	75	37	66	30	60	1114	610	
ES580/580L-04-037G/045P-3/B	95	133	91	45	79	37	60	1140	610	F6
ES580/580L-04-045G/055P-3/B	120	168	115	55	94	45	60	1200	610	
ES580/580L-05-055G/075P-3/B	162	227	155	75	116	55	60	1440	610	F7
ES580/580L-05-075G/090P-3/B	185	222	178	90	160	75	60	1940	610	
ES580/580L-05-090G/110P-3/B	225	270	215	110	179	90	67	2200	850	F8
ES580/580L-06-110G/132P-3	272	326	261	132	215	110	68	3300	1275	
ES580/580L-06-132G/160P-3	320	384	310	160	259	132	68	3850	1275	F9
ES580/580L-07-160G/200P-3	375	450	387	200	314	160	75	4100	1800	
ES580/580L-07-200G/220P-3	450	540	427	220	387	200	75	4600	1800	F8
ES580/580L-07-220G/250P-3	487	584	450	250	427	220	75	5100	1800	
ES580/580L-08-250G/280P-3	546	628	525	280	481	250	68	5782	2190	F9
ES580/580L-08-280G/315P-3	624	718	600	315	550	280	68	6252	2190	
ES580/580L-08-315G/355P-3	686	789	660	355	616	315	68	7866	2190	F9
ES580/580L-09-355G/400P-3	760	874	720	400	650	355	75	9100	2700	
ES580/580L-09-400G/450P-3	865	995	810	450	720	400	75	9900	2700	F9
ES580/580L-09-450G/500P-3	950	1093	870	500	810	450	75	10500	2700	
ES580/580L-09-500G/560P-3	1100	1265	980	560	870	500	75	11500	2700	F9
ES580/580L-09-560G/630P-3	1200	1380	1060	630	980	560	75	12600	2700	
ES580/580L-10-630G/710P-3	1350	1450	1320	710	1200	630	75	14500	3600	C10
ES580/580L-10-710G/800P-3	1500	1600	1450	800	1320	710	75	16800	3600	

Note: Rated power is measured under rated voltage 380V

## 500V 3ph rated voltage( adapt to the working voltage range 480~525V ±15%)

Model Code	Rated Value		General Load Application		Heavy Load Application		Noise Level dBA	Heat Radiation W	Air Volume m³/h	Dimension
	I <sub>N</sub> (A)	I <sub>max</sub> (A)	I <sub>Ld</sub> (A)	P <sub>Ld</sub> (kW)	I <sub>Hd</sub> (A)	P <sub>Hd</sub> (kW)				
ES580-04-015G/018P-5	35	64	33	18.5	27	15	60	890	610	F4
ES580-04-018G/022P-5	44	70	41	22	35	18.5	60	1114	610	
ES580-04-022G/030P-5	49	71	48	30	45	22	60	1140	610	
ES580-04-030G/037P-5	61	104	58	37	52	30	60	1200	610	
ES580-05-037G/045P-5	80	124	80	45	65	37	67	1440	610	F5
ES580-05-045G/055P-5	98	168	93	55	86	45	68	1940	610	
ES580-05-055G/075P-5	119	198	113	75	100	55	68	2200	850	F6
ES580-06-075G/090P-5	142	200	142	90	121	75	68	3300	1275	
ES580-06-090G/110P-5	175	220	165	110	150	90	68	3850	1275	F7
ES580-07-110G/132P-5	220	240	215	132	175	110	75	4100	1800	
ES580-07-132G/160P-5	271	320	245	160	220	132	75	4600	1800	F8
ES580-07-160G/200P-5	290	350	265	200	250	160	75	5100	1800	
ES580-08-200G/220P-5	300	360	295	220	270	200	68	5782	2190	F9
ES580-08-220G/250P-5	330	360	325	250	300	220	68	6252	2190	
ES580-08-250G/280P-5	370	480	360	280	330	250	68	7866	2190	C10
ES580-09-280G/315P-5	430	520	420	315	385	280	75	9100	2700	
ES580-09-315G/355P-5	470	655	455	355	430	315	75	9900	2700	C11 <sup>4)</sup>
ES580-09-355G/400P-5	522	700	505	400	470	355	75	10500	2700	
ES580-09-400G/450P-5	590	800	571	450	535	400	75	11500	2700	C10
ES580-09-450G/500P-5	721	820	710	500	600	450	75	12600	2700	
ES580-10-500G/560P-5	900	1000	790	560	680	500	75	13820	3600	C11 <sup>4)</sup>
ES580-10-560G/630P-5	1080	1200	880	630	770	560	75	14850	3600	
ES580-11-630G/710P-5	1160	1750	1100	710	900	630	75	20000	7200	C11 <sup>4)</sup>
ES580-11-710G/800P-5	1450	2000	1200	800	1100	710	75	26000	7200	
ES580-11-800G/900P-5	1650	2200	1350	900	1200	800	75	32000	7200	

Note: Rated power is measured under rated voltage 500V

## 690V 3ph rated voltage ( adapt to the working voltage range 660~690V ±15% )

Model Code	Rated Value		General Load Application		Heavy Load Application		Noise Level dBA	Heat Radiation W	Air Volume m³/h	Dimension
	I <sub>N</sub> (A)	I <sub>max</sub> (A)	I <sub>Ld</sub> (A)	P <sub>Ld</sub> (kW)	I <sub>Hd</sub> (A)	P <sub>Hd</sub> (kW)				
ES580/580L-04-015G/018P-6	22	44	21	18.5	18	15	60	550	610	F4
ES580/580L-04-018G/022P-6	26	54	25	22	22	18.5	60	660	610	
ES580/580L-04-022G/030P-6	35	64	33	30	27	22	60	890	610	
ES580/580L-04-030G/037P-6	44	70	41	37	35	30	60	1114	610	
ES580/580L-04-037G/045P-6	49	71	48	45	45	37	60	1140	610	F5
ES580/580L-04-045G/055P-6	61	104	58	55	52	45	60	1200	610	
ES580/580L-05-055G/075P-6	80	124	80	75	65	55	67	1440	610	F6
ES580/580L-05-075G/090P-6	98	168	93	90	86	75	68	1940	610	
ES580/580L-05-090G/110P-6	119	198	113	110	100	90	68	2200	850	F7
ES580/580L-06-110G/132P-6	142	200	142	132	121	110	68	3300	1275	
ES580/580L-06-132G/160P-6	175	220	165	160	150	132	68	3850	1275	F8
ES580/580L-07-160G/200P-6	220	240	215	200	175	160	75	4100	1800	
ES580/580L-07-200G/220P-6	271	320	245	220	220	200	75	4600	1800	F9
ES580/580L-07-220G/250P-6	290	350	265	250	250	220	75	5100	1800	
ES580/580L-08-250G/280P-6	300	360	295	280	270	250	68	5782	2190	C10
ES580/580L-08-280G/315P-6	330	360	325	315	300	280	68	6252	2190	
ES580/580L-08-315G/355P-6	370	480	360	355	330	315	68	7866	2190	C11 <sup>4)</sup>
ES580/580L-09-355G/400P-6	430	520	420	400	385	355	75	9100	2700	
ES580/580L-09-400G/450P-6	470	655	455	450	430	400	75	9900	2700	F9
ES580/580L-09-450G/500P-6	522	700	505	500	470	450	75	10500	2700	
ES580/580L-09-500G/560P-6	590	800	571	560	535	500	75	11500	2700	F7
ES580/580L-09-560G/630P-6	721	820	710	630	600	560	75	12600	2700	
ES580/580L-10-630G/710P-6	900	1000	790	710	680	630	75	13820	3600	F8
ES580/580L-10-710G/800P-6	1080	1200	880	800	770	710	75	14850	3600	
ES580/580L-11-800G/1100P-6	1160	1750	1115	1100	900	800	75	20000	7200	C10
ES580/580L-11-1100G/1250P-6	1450	2000	1250	1250	1114	1100	75	26000	7200	
ES580/580L-11-1250G/1400P-6	1650	2200	1400	1400	1250	1250	75	32000	7200	

Note: Rated power is measured under rated voltage 690V

## Selection of ES850/850L Products

- 1) Excellent performance for speed & torque closed loop control
- 2) Comprehensive and systematic protection functions
- 3) Intelligent LCD keyboard included in standard configuration
- 4) Built-in various industry application standard macros
- 5) Support multiple encoders for high performance and high precision control



## 220V 3ph rated voltage( adapt to the working voltage range 208~240V ±15% )

Model Code	Rated Value		General Load Application		Heavy Load Application		Noise Level dBA	Heat Radiation W	Air Volume m³/h	Dimension
	I <sub>N</sub> (A)	I <sub>max</sub> (A)	I <sub>Ld</sub> (A)	P <sub>Ld</sub> (kW)	I <sub>Hd</sub> (A)	P <sub>Hd</sub> (kW)				
ES850-01-0K4G/0K7P-2B	5.2	7	5	0.75	2.5	0.37	45	40	89	F1
ES850-01-0K7G/1K5P-2B	6.3	9	6	1.5	4.2	0.75	45	76	89	
ES850-01-1K5G/2K2P-2B	10.5	15	9.8	2.2	5.6	1.5	45	97	89	
ES850-01-2K2G/4K0P-2B	18.2	25	17.5	4	14.5	2.2	45	172	130	F2
ES850-02-4K0G/5K5P-2B	26	36	25	5.5	17.6	4	45	325	130	
ES850-02-5K5G-2B	28	35	\	\	25	5.5	45	420	130	F2A
ES850-02A-5K5G/7K5P-2B	37	50	35	7.5	25	5.5	52	450	175	
ES850-02A-7K5G/011P-2B	41	57	38.6	11	35	7.5	52	450	175	F3
ES850-03-7K5G/011P-2B	41	57	38.6	11	35	7.5	57	550	306	
ES850-03-011G/015P-2B	63.5	89	61	15	48	11	57	890	306	F4
ES850-04-015G/018P-2	78	109	75	18.5	66	15	60	1114	610	
ES850-04-018G/022P-2	95	133	91	22	79	18.5	60	1140	610	F5
ES850-04-022G/030P-2	120	168	115	30	94	22	60	1200	610	
ES850-05-030G/037P-2	162	227	155	37	116	30	60	1440	610	F6
ES850-05-037G/045P-2	185	222	178	45	160	37	60	1940	610	
ES850-05-045G/055P-2	225	270	215	55	179	45	67	2200	850	
ES850-06-055G/075P-2	272	326	261	75	215	55	68	3300	1275	

Note: Rated power is measured under rated voltage 220V

## 380V 3ph rated voltage ( adapt to the working voltage range 380~460V ±15% )

Model Code	Rated Value		General Load Application		Heavy Load Application		Noise Level dBA	Heat Radiation W	Air Volume m³/h	Dimension
	I <sub>N</sub> (A)	I <sub>max</sub> (A)	I <sub>Ld</sub> (A)	P <sub>Ld</sub> (kW)	I <sub>Hd</sub> (A)	P <sub>Hd</sub> (kW)				
ES850/850L-01-0K7G/1K5P-3B	5.2	7	5	1.5	2.5	0.75	45	40	89	F1
ES850/850L-01-1K5G/2K2P-3B	6.3	9	6	2.2	4.2	1.5	45	76	89	
ES850/850L-01-2K2G/4K0P-3B	10.5	15	9.8	4	5.6	2.2	45	97	89	
ES850/850L-01-4K0G/5K5P-3B	14	20	13.5	5.5	10.5	4	45	172	89	F2
ES850/850L-01-5K5G/7K5P-3B	18.2	25	17.5	7.5	14.5	5.5	45	210	130	
ES850/850L-02-7K5G/011P-3B	26	36	25	11	17.6	7.5	45	325	130	F2A
ES850/850L-02-011G-3B	28	35	26	15	25	11	45	420	130	
ES850/850L-02A-011G/015P-3B	37	50	35	15	25	11	52	470	175	F3
ES850/850L-02A-015G/018P-3B	41	57	38.6	18.5	35	15	52	550	175	
ES850/850L-03-015G/018P-3B	41	57	38.6	18.5	35	15	57	550	306	F4
ES850/850L-03-018G/022P-3B	48	67	46	22	41	18.5	57	660	306	
ES850/850L-03-022G/030P-3B	63.5	89	61	30	48	22	57	890	306	F5
ES850/850L-04-030G/037P-3/B	78	109	75	37	66	30	60	1114	610	
ES850/850L-04-037G/045P-3/B	95	133	91	45	79	37	60	1140	610	F6
ES850/850L-04-045G/055P-3/B	120	168	115	55	94	45	60	1200	610	
ES850/850L-05-055G/075P-3/B	162	227	155	75	116	55	60	1440	610	F7
ES850/850L-05-075G/090P-3/B	185	222	178	90	160	75	60	1940	610	
ES850/850L-05-090G/110P-3/B	225	270	215	110	179	90	67	2200	850	F8
ES850/850L-06-110G/132P-3	272	326	261	132	215	110	68	3300	1275	
ES850/850L-06-132G/160P-3	320	384	310	160	259	132	68	3850	1275	F9
ES850/850L-07-160G/200P-3	375	450	387	200	314	160	68	4100	1800	
ES850/850L-07-200G/220P-3	450	540	427	220	387	200	68	4600	1800	F8
ES850/850L-07-220G/250P-3	487	584	450	250	427	220	68	5100	1800	
ES850/850L-08-250G/280P-3	546	628	525	280	481	250	68	5782	2190	C10
ES850/850L-08-280G/315P-3	624	718	600	315	550	280	68	6252	2190	
ES850/850L-08-315G/355P-3	686	789	660	355	616	315	68	7866	2190	F9
ES850/850L-09-355G/400P-3	760	874	720	400	650	355	68	9100	2700	
ES850/850L-09-400G/450P-3	865	995	810	450	720	400	68	9900	2700	F7
ES850/850L-09-450G/500P-3	950	1093	870	500	810	450	68	10500	2700	
ES850/850L-09-500G/560P-3	1100	1265	980	560	870	500	68	11500		

500V 3ph rated voltage( adapt to the working voltage range 480~525V ±15% )

Model Code	Rated Value		General Load Application		Heavy Load Application		Noise Level	Heat Radiation	Air Volume	Dimension
	I <sub>N</sub> (A)	I <sub>max</sub> (A)	I <sub>Ld</sub> (A)	P <sub>Ld</sub> (kW)	I <sub>Hd</sub> (A)	P <sub>Hd</sub> (kW)				
ES850-04-015G/018P-5	35	64	33	18.5	27	15	60	890	610	F4
ES850-04-018G/022P-5	44	70	41	22	35	18.5	60	1114	610	
ES850-04-022G/030P-5	49	71	48	30	45	22	60	1140	610	
ES850-04-030G/037P-5	61	104	58	37	52	30	60	1200	610	F5
ES850-05-037G/045P-5	80	124	80	45	65	37	67	1440	610	
ES850-05-045G/055P-5	98	168	93	55	86	45	68	1940	610	
ES850-05-055G/075P-5	119	198	113	75	100	55	68	2200	850	F6
ES850-06-075G/090P-5	142	200	142	90	121	75	68	3300	1275	
ES850-06-090G/110P-5	175	220	165	110	150	90	68	3850	1275	
ES850-07-110G/132P-5	220	240	215	132	175	110	75	4100	1800	F7
ES850-07-132G/160P-5	271	320	245	160	220	132	75	4600	1800	
ES850-07-160G/200P-5	290	350	265	200	250	160	75	5100	1800	
ES850-08-200G/220P-5	300	360	295	220	270	200	68	5782	2190	F8
ES850-08-220G/250P-5	330	360	325	250	300	220	68	6252	2190	
ES850-08-250G/280P-5	370	480	360	280	330	250	68	7866	2190	
ES850-09-280G/315P-5	430	520	420	315	385	280	75	9100	2700	F9
ES850-09-315G/355P-5	470	655	455	355	430	315	75	9900	2700	
ES850-09-355G/400P-5	522	700	505	400	470	355	75	10500	2700	
ES850-09-400G/450P-5	590	800	571	450	535	400	75	11500	2700	C10
ES850-09-450G/500P-5	721	820	710	500	600	450	75	12600	2700	
ES850-10-500G/560P-5	900	1000	790	560	680	500	75	13820	3600	
ES850-10-560G/630P-5	1080	1200	880	630	770	560	75	14850	3600	C11 <sup>4)</sup>
ES850-11-630G/710P-5	1160	1750	1100	710	900	630	75	20000	7200	
ES850-11-710G/800P-5	1450	2000	1200	800	1100	710	75	26000	7200	
ES850-11-800G/900P-5	1650	2200	1350	900	1200	800	75	32000	7200	

Note: Rated power is measured under rated voltage 500V

690V 3ph rated voltage ( adapt to the working voltage range 660~690V ±15% )

Model Code	Rated Value		General Load Application		Heavy Load Application		Noise Level	Heat Radiation	Air Volume	Dimension
	I <sub>N</sub> (A)	I <sub>max</sub> (A)	I <sub>Ld</sub> (A)	P <sub>Ld</sub> (kW)	I <sub>Hd</sub> (A)	P <sub>Hd</sub> (kW)				
ES850/850L-04-015G/018P-6	22	44	21	18.5	18	15	60	550	610	F4
ES850/850L-04-018G/022P-6	26	54	25	22	22	18.5	60	660	610	
ES850/850L-04-022G/030P-6	35	64	33	30	27	22	60	890	610	
ES850/850L-04-030G/037P-6	44	70	41	37	35	30	60	1114	610	F5
ES850/850L-04-037G/045P-6	49	71	48	45	45	37	60	1140	610	
ES850/850L-04-045G/055P-6	61	104	58	55	52	45	60	1200	610	
ES850/850L-05-055G/075P-6	80	124	80	75	65	55	67	1440	610	F6
ES850/850L-05-075G/090P-6	98	168	93	90	86	75	68	1940	610	
ES850/850L-05-090G/110P-6	119	198	113	110	100	90	68	2200	850	
ES850/850L-06-110G/132P-6	142	200	142	132	121	110	68	3300	1275	F7
ES850/850L-06-132G/160P-6	175	220	165	160	150	132	68	3850	1275	
ES850/850L-07-160G/200P-6	220	240	215	200	175	160	75	4100	1800	
ES850/850L-07-200G/220P-6	271	320	245	220	220	200	75	4600	1800	F8
ES850/850L-07-220G/250P-6	290	350	265	250	250	220	75	5100	1800	
ES850/850L-08-250G/280P-6	300	360	295	280	270	250	68	5782	2190	
ES850/850L-08-280G/315P-6	330	360	325	315	300	280	68	6252	2190	F9
ES850/850L-08-315G/355P-6	370	480	360	355	330	315	68	7866	2190	
ES850/850L-09-355G/400P-6	430	520	420	400	385	355	75	9100	2700	
ES850/850L-09-400G/450P-6	470	655	455	450	430	400	75	9900	2700	C10
ES850/850L-09-450G/500P-6	522	700	505	500	470	450	75	10500	2700	
ES850/850L-09-500G/560P-6	590	800	571	560	535	500	75	11500	2700	
ES850/850L-09-560G/630P-6	721	820	710	630	600	560	75	12600	2700	C11 <sup>4)</sup>
ES850/850L-10-630G/710P-6	900	1000	790	710	680	630	75	13820	3600	
ES850/850L-10-710G/800P-6	1080	1200	880	800	770	710	75	14850	3600	
ES850/850L-11-800G/1100P-6	1160	1750	1115	1100	900	800	75	20000	7200	
ES850/850L-11-1100G/1250P-6	1450	2000	1250	1250	1114	1100	75	26000	7200	
ES850/850L-11-1250G/1400P-6	1650	2200	1400	1400	1250	1250	75	32000	7200	

Note: Rated power is measured under rated voltage 690V

Selection of ES850S Products

- 1) Support driving asynchronous motor and permanent magnet synchronous motor
- 2) The highest output frequency can reach 1500Hz;
- 3) Support multiple encoders and fieldbus;
- 4) With high precise speed and position control;
- 5) with the function of fixed length and fixed angle
- 6) Support pulse input and pulse output



Selection of ES850S Products

380V 3ph rated voltage( adapt to the working voltage range 380~460V ±15% )

Model Code	Rated Value		General Load Application		Heavy Load Application		Noise Level	Heat Radiation	Air Volume	Dimension
	I <sub>N</sub> (A)	I <sub>max</sub> (A)	I <sub>Ld</sub> (A)	P <sub>Ld</sub> (kW)	I <sub>Hd</sub> (A)	P <sub>Hd</sub> (kW)				
ES850S-01-0K7G/1K5P-3B	5.2	7	5	1.5	2.5	0.75	45	40	89	F1
ES850S-01-1K5G/2K2P-3B	6.3	9	6	2.2	4.2	1.5	45	76	89	
ES850S-01-2K2G/4K0P-3B	10.5	15	9.8	4	5.6	2.2	45	97	89	
ES850S-01-4K0G/5K5P-3B	14	20	13.5	5.5	10.5	4	45	172	89	F2
ES850S-01-5K5G/7K5P-3B	18.2	25	17.5	7.5	14.5	5.5	45	210	130	
ES850S-02-7K5G/011P-3B	26	36	25	11	17.6	7.5	45	325	130	
ES850S-02-011G-3B	28	35	26	15	25	11	45	420	130	F2A
ES850S-02A-011G/015P-3B	37	50	35	15	25	11	52	470	175	
ES850S-02A-015G/018P-3B	41	57	38.6	18.5	35	15	52	550	175	
ES850S-03-015G/018P-3B	41	57	38.6	18.5	35	15	57	550	306	F3
ES850S-03-018G/022P-3B	48	67	46	22	41	18.5	57	660	306	
ES850S-03-022G/030P-3B	63.5	89	61	30	48	22	57	890	306	
ES850S-04-030G/037P-3/B	78	109	75	37	66	30	60	1114	610	F4
ES850S-04-037G/045P-3/B	95	133	91	45	79	37	60	1140	610	
ES850S-04-045G/055P-3/B	120	168	115	55	94	45	60	1200	610	
ES850S-05-055G/075P-3/B	162	227	155	75	116	55	60	1440	610	F5
ES850S-05-075G/090P-3/B	185	222	178	90	160	75	60	1940	610	
ES850S-05-090G/110P-3/B	225	270	215	110	179	90	67	2200	850	
ES850S-06-110G/132P-3	272	326	261	132	215	110	68	3300	1275	F6
ES850S-06-132G/160P-3	320	384	310	160	259	132	68	3850	1275	
ES850S-07-160G/200P-3	375	450	387	200	314	160	75	4100	1800	
ES850S-07-200G/220P-3	450	540	427	220	387	200	75	4600	1800	F7
ES850S-07-220G/250P-3	487	584	450	250	427	220	75	5100	1800	
ES850S-08-250G/280P-3	546	628	525	280	481	250	68	5782	2190	
ES850S-08-280G/315P-3	624	718	600	315	550	280	68	6252	2190	F8
ES850S-08-315G/355P-3	686	789	660	355	616	315	68	7866	2190	
ES850S-09-355G/400P-3	760	874	720	400	650	355	75	9100	2700	
ES850S-09-400G/450P-3	865	995	810	450	720	400	75	9900	2700	F9
ES850S-09-450G/500P-3	950	1093	870	500	810	450	75	10500	2700	
ES850S-09-500G/560P-3	1100	1265	980	560	870	500	75	11500	2700	
ES850S-09-560G/630P-3	1200	1380	1060	630	980	560	75	12600	2700	C10
ES850S-10-630G/710P-3	1350	1450	1320	710	1200	630	75	14500	3600	
ES850S-10-710G/800P-3	1500	1600	1450	800	1320	710	75	16800	3600	

Note: Rated power is measured under rated voltage 380V

# Installation Dimension

# Optional Accessories

Dimensions and installation schematic diagram of ES355 series plastics/sheet metal structure

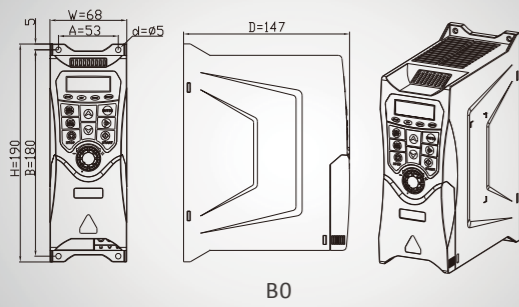

B0

Dimensions and installation schematic diagram of ES 560 series plastics/sheet metal structure

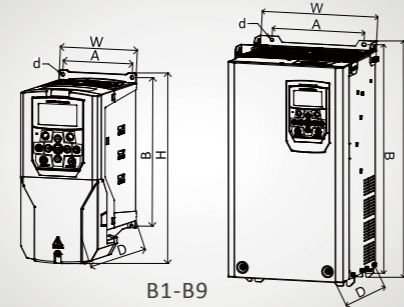

B1-B9

Dimensions and installation schematic diagram of ES350 series plastics/sheet metal structure

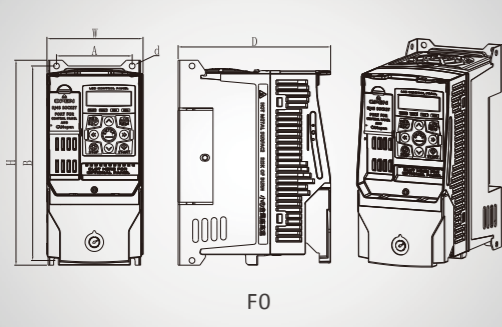

F0

Dimensions and installation schematic diagram of ES580/850 series plastics/sheet metal structure

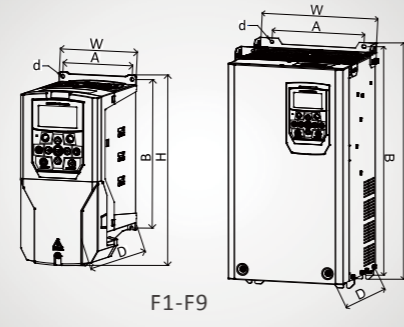

F1-F9

Shape and dimensions of the opening for directly mounting the control keyboard/bracket to the door

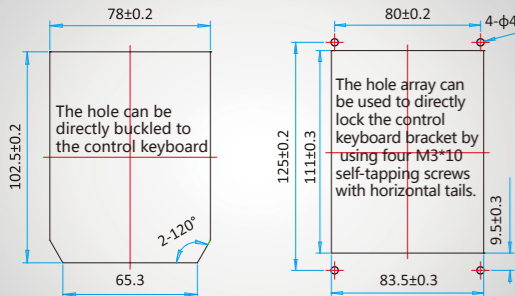

Structural dimensions and installation diagram for C10 cabinet

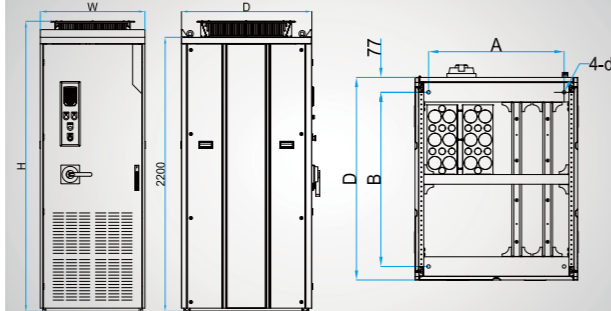

Dimension	Installation Hole Width Spacing A (mm)	Installation Hole Height Spacing B (mm)	Installation Hole Sized (mm)	Appearance Width W (mm)	Appearance Height H (mm)	Appearance Thickness D (mm)	Weight (Kg)
B0	53	180	5.0	68	190	147	1.5
B1	110	222	5.5	122	276	172	3.7
B2	140	238	6.0	155	292	172	4.8
B2A	160	296	6.0	175	336	192	5.1
B3	150	368	7.0	180	420	216	12.6
B4	200	479	6.5	225	495	221	22
B5	250	260	12.0	355	670	260	65
B6	357/75*	761	11.0	390	790	278	95
B7	357/115*	973/977	11.0	390	1001	295	140
B8	490/200*	1280	13.0	537	1035	340	200
B9	490/240*	1420	13.0	537	1455	380	240
F0	65	168	5.0	82	176	131	1.8
F1	110	222	5.5	122	276	172	3.7
F2	140	238	6.0	155	292	172	4.8
F2A	160	296	6.0	175	336	192	5.1
F3	150	368	7.0	180	420	216	12.6
F4	200	479	6.5	255	495	221	22
F5	250	650	12.0	355	670	260	65
F6	357/75 <sup>1)</sup>	761	11.0	390	790	278	95
F7	357/115 <sup>1)</sup>	973	11.0	390	1001	295	140
F8	490/200 <sup>1)</sup>	1280	13.0	537	1305	340	200
F9	490/240 <sup>1)</sup>	1420	13.0	537	1455	380	240
C10	700	900	18.0	840	2330	1050	500

Note: 1) Indicates hole spacing for forwarding installation /hole spacing for blade-type lateral installation hole (preferred design scheme);

Legend	Model	Accessory and Main Function
	ESX-04-X/X-3B	The built-in braking unit function is optional for F4 series products and is represented with [B] at the end of model.
	ESX-05-X/X-3B	The built-in braking unit function is optional for F5 series products and is represented with [B] at the end of model.
	ES-CM-PD	Profibus-DP card, adapt to DB-9 pin serial port.
	ES-CM-PN	Profinet communication card
	ES-CM-ET	EtherCAT communication card
	ES-CM-CAN	Canopen.
	ES-PG-OC	Collector open encoder interface card, adapting to 12V power, with position control pulse input/output.
	ES-PG-DF	Differential encoder interface card, adapting to 5V power, with position control pulse input/output.
	ES-PG-DF1	Differential encoder interface card (support 5V/12V)
	ES-PG-RT	Rotary transformer encoder interface card, with position control pulse input/output.
	ES-PG-SN	Sin-Cos encoder interface card, adapting to 5V power, with position control pulse input/output.
	ES-RU-DTC	The voltage capture card of the power grid is connected to the power grid and is used to detect real-time phase voltage and phase of the power grid, so as to achieve VF and WF switching or energy feedback.
	ES-RU-PL	Power off synchronization function card.
	ES-PG-SN1	Sin-cos encoder interface card (subdivision and frequency division)
	ES-PG-ABS	HEIDENHAIN Absolute Encoder Interface Card
	ES850-PG-DC	Power off synchronization function card.
	ES-CP-MU	24V-POW (external 24V power supply card)
	ES-CP-MUE	LED keyboard is optional.
	ES-CP-SU	Extended bracket of the control keyboard, which is applicable to installation of the LCD keyboard cabinet door.
	ES-SU-F6	Applicable to the floor-mounted installation base for F6 and F7 models.
	ES-SU-F8	Applicable to the floor-mounted installation base for F8 and F9 models.
	ES-RP-01	Universal high-performance rotary single-turn 5K potentiometer with the rotary knob (universal model: RV24YN 20SB502).
	ES-CB-F0	Incoming box, which is applicable to F0 models, in order to raise the closed protective capability to IP40.
	ES850-STO	Safe torque stop function.
	ES850-TER2	Constant pressure water supply interface board.
	ES850-TER3	Special interface board for travelling crane, support three-way relay control.
	ES850-TER4	Inverter automatic cleaning kit, including interface board and fan.
	PC Debug software	After installing this software, visual parameter debugging, fault display, waveform detection, etc. can be easily realized through the PC terminal.

## Standard Wiring Diagram 1 (Applicable to ES355/355L Series and B0)

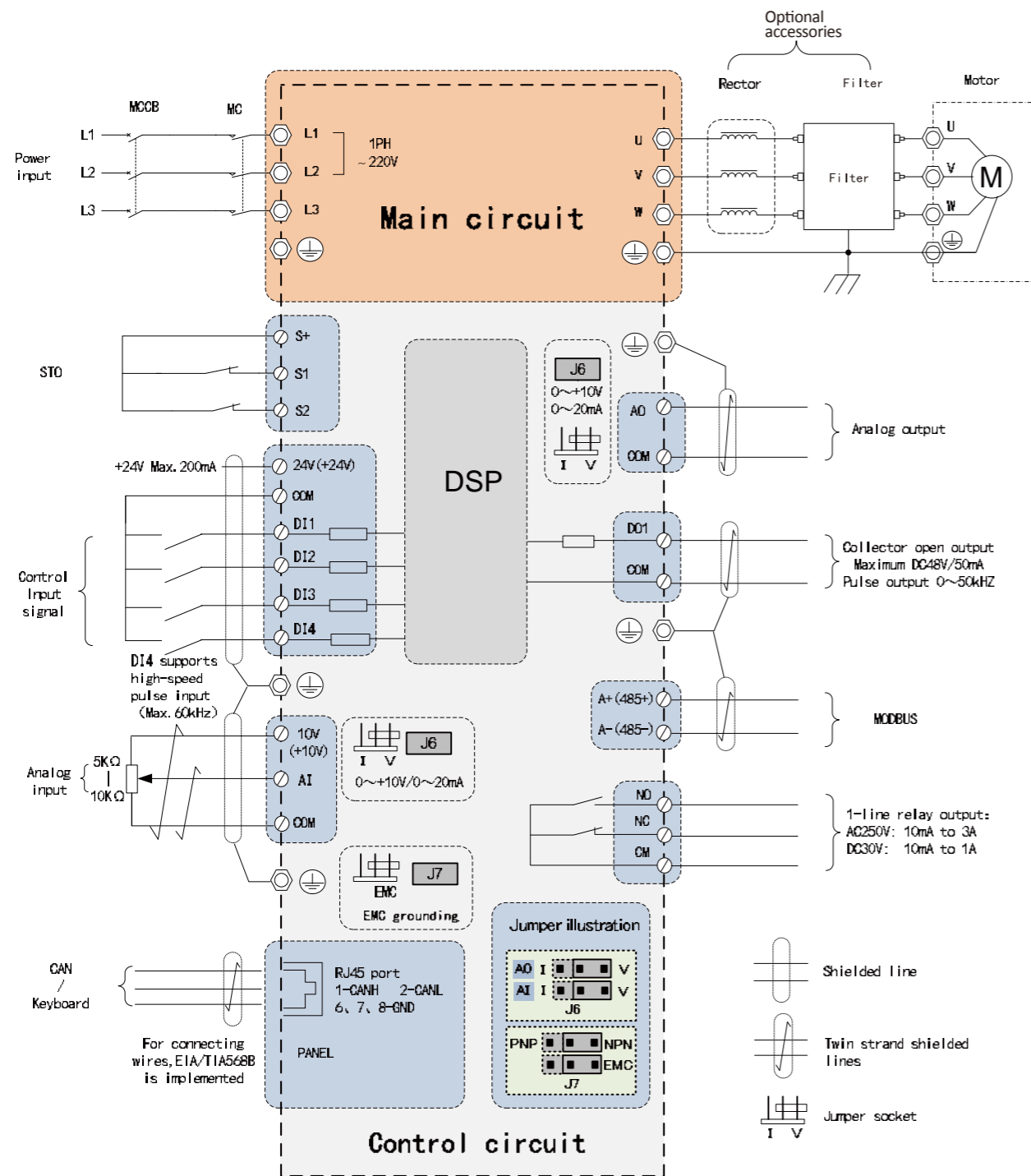

## Standard Wiring Diagram 2 (Applicable to ES560/560L Series and B1-B9)

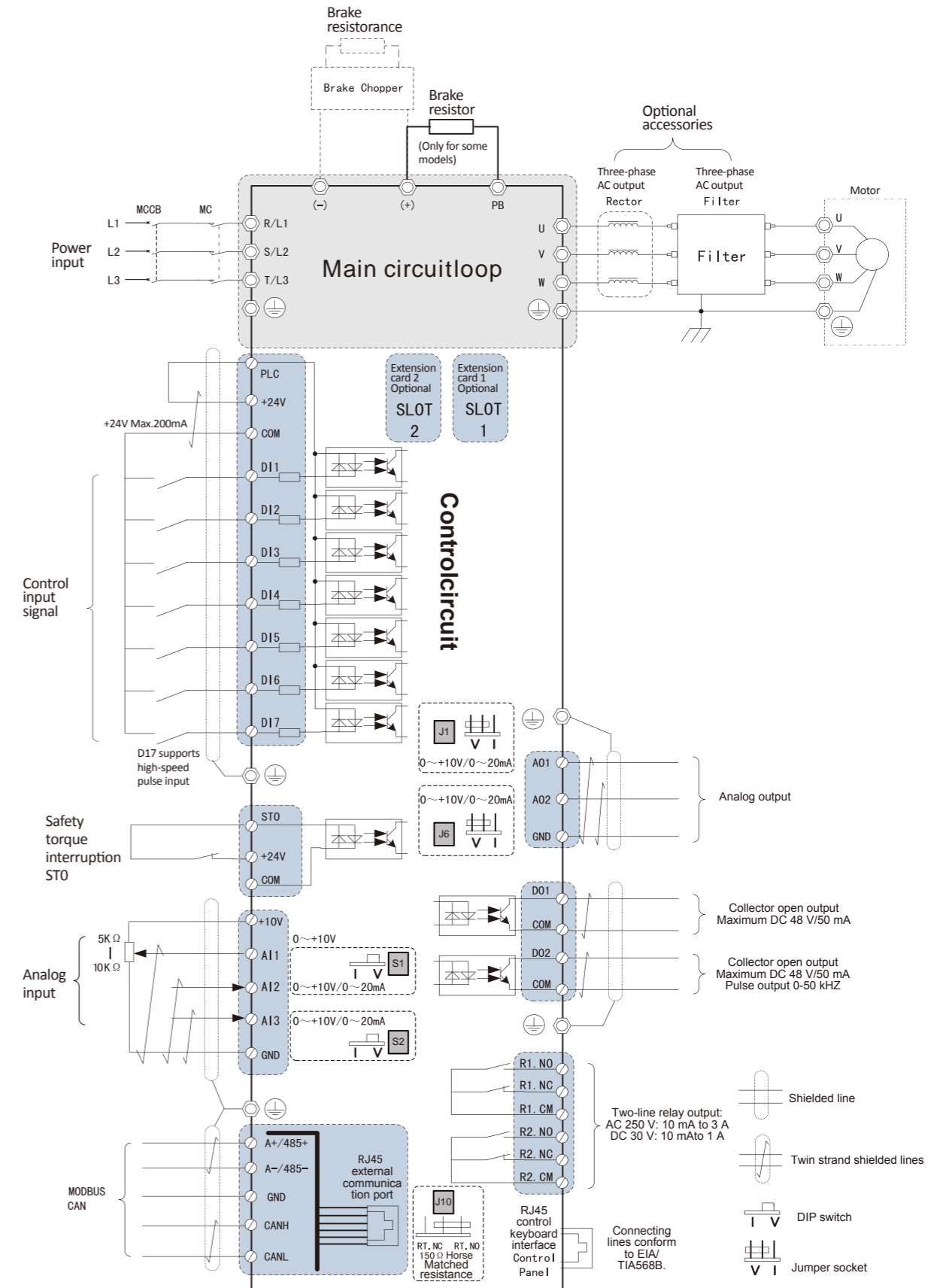

Standard Wiring Diagram 3 (Applicable to ES350/350L Series and F0)

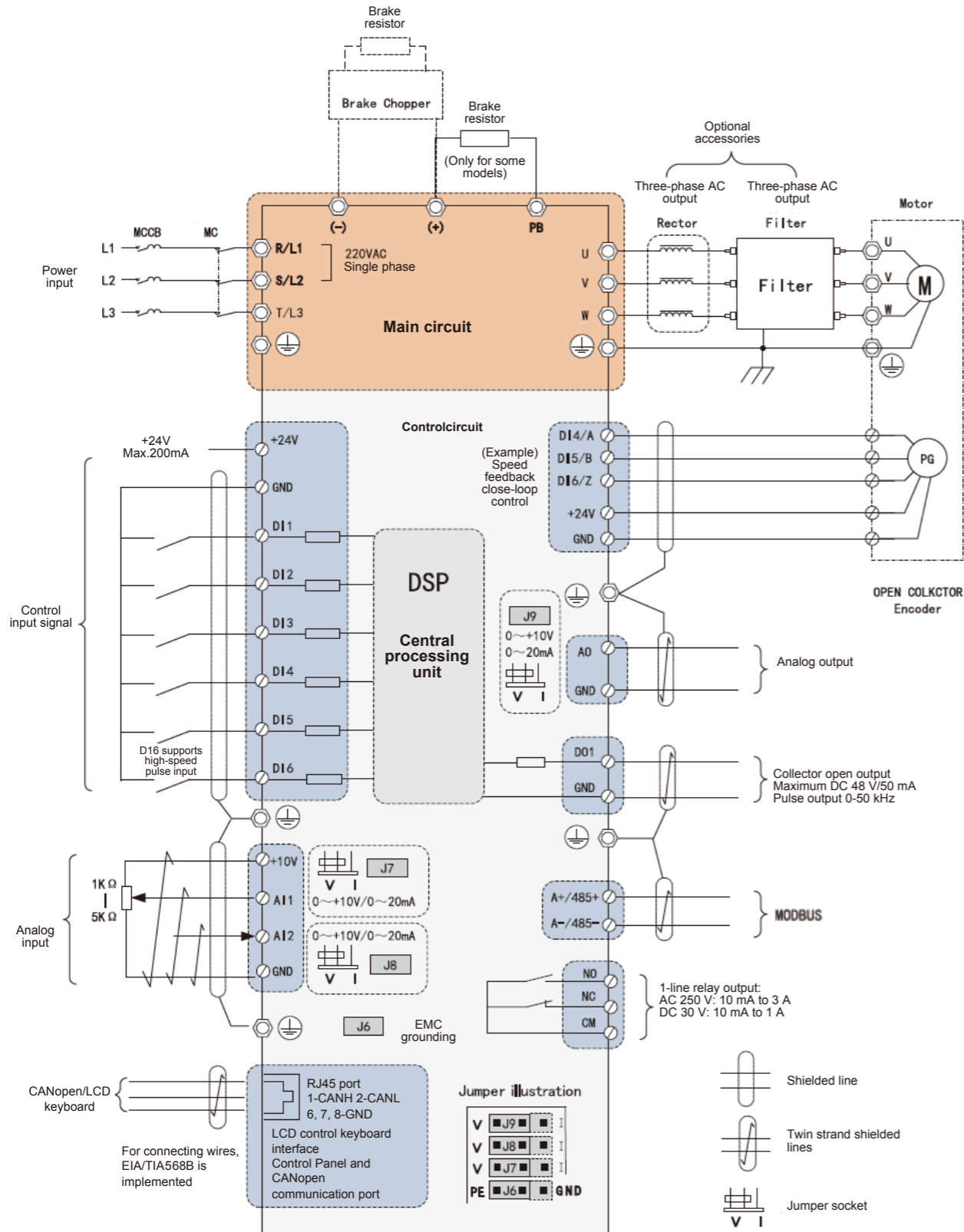

Standard Wiring Diagram 4 (Applicable to ES580/580L/850/850L/850S Series and F1-F9)

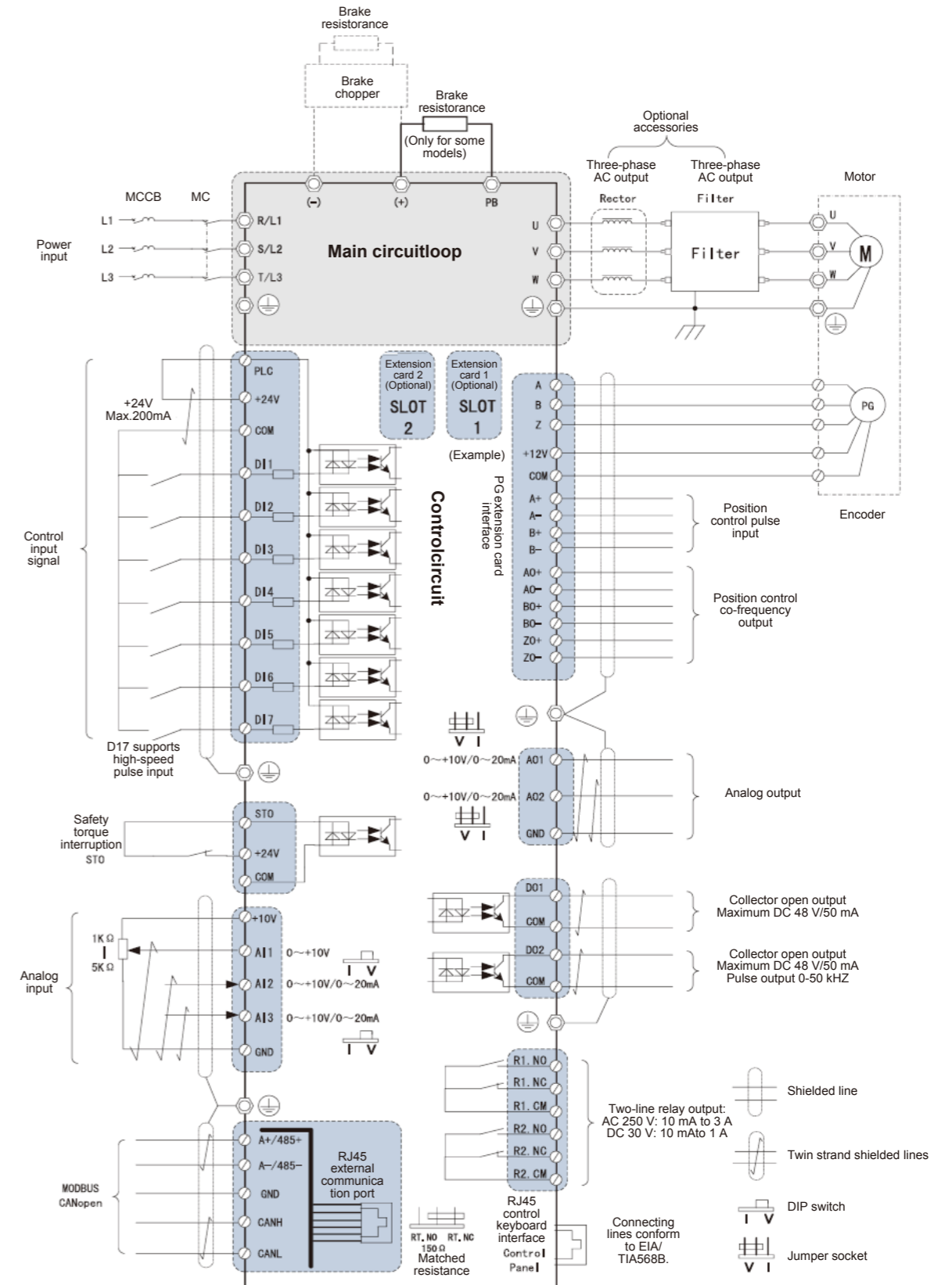

★ ES580 /ES580L not suitable for PG feedback

## Advantageous Industry Applications

### Lifting Machinery

- ◇ Fast response speed and large startup torque properly alleviate vibrations at startup.
- ◇ Zero-speed clasp brake and zero-speed open brake completely eliminate hook sliding and back flush.
- ◇ Low torque pulse ensures more reliable operation of the device; especially in construction elevators, the device makes taking the elevators more conformable.
- ◇ All-round protection functions (frequency converter, motor, brake unit) and overload torque detection function prevent operations beyond the specification or on a mechanical failure.
- ◇ Compact structure design is adopted and the built-in brake unit (for below 90kW) is optional.
- ◇ The Smart drive function facilitates operations (easy for commissioning and maintenance), and helps save labor costs and time.
- ◇ Intelligent LCD keyboard, real-time monitoring of key information, convenient man-machine interactions are provided.
- ◇ The voltage operation range is wide (-15% to +15%).

### Typical Applications



Bridge crane



Tower crane



Hoist

### Metal and Stone Processing

- ◇ Low frequency and strong torque, steady speed and high precision.
- ◇ The device can decelerate quickly to stop during a power failure to prevent long-time mechanical inertia rotation, which is safer.
- ◇ High overload capacity (1.5 seconds at 200% rated load), good overvoltage suppression (especially in punching).
- ◇ High protection grade (IP40), closed circuit structure design, thickening process of multiple conformal coatings, good physical environmental adaptability
- ◇ Smartdrive function, which can be used in most servo applications.
- ◇ Smart drive function, which facilitates operations (easy for commissioning and maintenance), and save labor costs and time.
- ◇ Intelligent LCD keyboard, real-time monitoring of key information, convenient man-machine interactions
- ◇ The fluctuation of speed is small when the converter is loaded suddenly.
- ◇ Capable of receiving various signal sources

### Typical Applications



Machine tools



Rotary cutter for the wood processing equipment



Punch of the metal processing equipment

### Cables, Winding

- ◇ Low frequency and strong torque, supporting low-speed startup with empty reel or full reels
- ◇ Fast response speed, steady and fast during startup/stop and acceleration and deceleration
- ◇ High steady-speed precision, constant tension control, steadier pendulum during the whole process
- ◇ High protection grade (IP40), closed circuit structure design, and thickening process of multiple conformal coatings, effectively preventing metal dusts
- ◇ F3 models and above, which can effectively reduce power higher harmonic and conduction radiation. Other optional accessories are not required to save space and reduce wiring
- ◇ Smartdrive function, avoiding complex commissioning, facilitating maintenance; saving labor costs and time
- ◇ Intelligent LCD keyboard, real-time monitoring of key information, convenient man-machine interactions

### Typical Applications



Coating machine



Straight wire drawing machine

### Fluid Machinery

- ◇ Intelligent commissioning: Intelligent setting of industry application parameters, intelligent V/F curve setting. Complex commissioning by professionals is not required to save labor and time.
- ◇ Compatible with synchronous motors  
energy greatly Used with synchronous motor, down sizing and light weight, saving  
Used with synchronous motor, down sizing and light weight, saving equipment room
- ◇ equipment room Built-in reactor for F3 and above models  
Other optional accessories are not required to save space and reduce wiring; The power higher harmonic and conduction and radiation can be effectively reduced.
- ◇ Good human-machine interface  
Real-time monitoring of key parameters; real-time and multi-line LCD display
- ◇ Speed search function: Rotations in the free running mode can be searched after power failure and startup, implementing easy start up.
- ◇ Greater energy saving effects, minimum unit power consumption in the case of equivalent torques

### Typical Applications



Air compressor



Fans & pumps

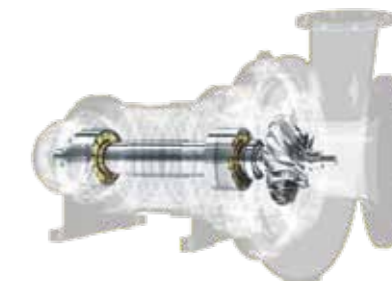

High Speed Maglev Blower

